

▶定格総荷重

- 定格総荷重とは、水平堅土上における転倒荷重の78%以内で、フックブロック、玉掛用ワイヤロープ等のつり具の質量を含んだ値です。
- 作業半径とはクレーン旋回中心よりつり上荷重の重心までの水平距離を意味します。
- 実際につり上げ得る荷重は定格総荷重から（主フック+玉掛用ワイヤロープ等のつり具）の質量を差し引いた値になります。
- 定格総荷重をつる場合にも風の影響、地盤の状態、作業速度その他安全作業に有害な状況がある時はオペレータは荷重の軽減、作業速度を遅くするなど状況に応じた判断をする責任があります。
- 表中の空欄の個所では作業を行うことができません。
- クレーン作業中はガントリを最高位置に立ててください。

- すべてのタワー（ジブ）長さにおける中間タワーブーム（ジブ）の構成は取扱説明書の指示を厳守してください。
- ジブ長さ27.4mにてボールフックの使用はできません。
- 64.1mタワーの自立、降下の際には、クローラの前端に敷板（ブロック）を敷いて下さい。
操作ミスなどによるつり荷の落下を防ぐため、クレーン作業では自由降下（フリーフォール）作業は行わないでください。
- 巻上げロープ巻掛本数に対する最大巻上荷重とフックの質量

| フック呼称 | | 35t | ボールフック |
|------------|-----|-------|--------|
| 最大巻上荷重 (t) | 1本掛 | 13.5 | 13.5 |
| | 2本掛 | 25.0 | - |
| フック質量 | | 0.90t | 0.45t |

※ジブ長さ27.4mでのボールフックの使用はできません。

▶フック巻上限界 (単位:m)

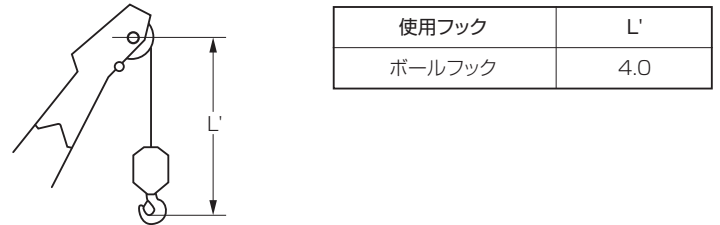
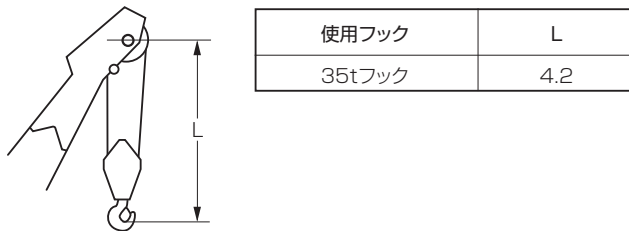

▶タワー長さ 36.6m

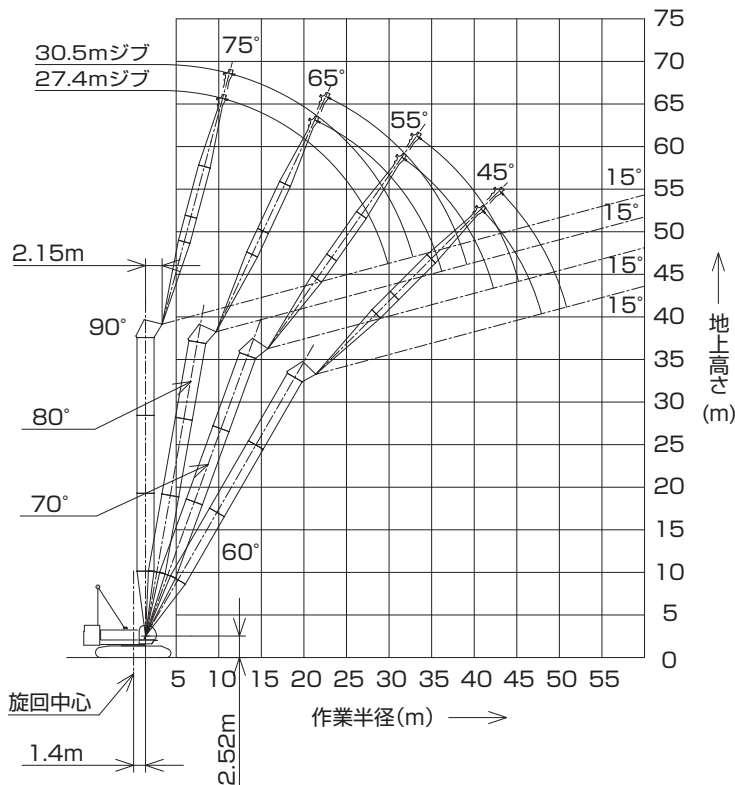

(単位:t)

| タワー長さm | 36.6 | | | | | | | | タワー長さm |
|--------|------------|------------|------------|------------|------------|------------|------------|-----|--------|
| ジブ長さm | 27.4 | | | | 30.5 | | | | ジブ長さm |
| タワー角度 | 90° | 80° | 70° | 60° | 90° | 80° | 70° | 60° | タワー角度 |
| 10.0 | 25.0/10.9m | | | | 25/11.7m | | | | 10.0 |
| 12.0 | 25.0 | | | | 25.0 | | | | 12.0 |
| 14.0 | 25.0 | | | | 25.0 | | | | 14.0 |
| 16.0 | 25.0 | | | | 25.0 | | | | 16.0 |
| 18.0 | 25.0 | | | | 24.2 | | | | 18.0 |
| 20.0 | 24.2 | 23.4/21.7m | | | 23.5 | | | | 20.0 |
| 22.0 | 23.2 | 23.2 | | | 22.7 | 21.9/23.0m | | | 22.0 |
| 24.0 | 21.0 | 21.0 | | | 21.0 | 21.0 | | | 24.0 |
| 26.0 | 18.6 | 18.6 | | | 18.6 | 18.6 | | | 26.0 |
| 28.0 | 16.0 | 16.8 | | | 16.7 | 16.7 | | | 28.0 |
| 30.0 | 11.2/29.9m | 15.2 | 14.1/31.9m | | 15.1 | 15.1 | | | 30.0 |
| 32.0 | | 14.0 | 14.0 | | 12.0 | 13.9 | 13.0/33.7m | | 32.0 |
| 34.0 | | 12.8 | 12.8 | | 10.6/32.8m | 12.7 | 12.7 | | 34.0 |
| 36.0 | | 11.8 | 11.8 | | | 11.7 | 11.7 | | 36.0 |
| 38.0 | | 11.8/36.2m | 11.1 | | | 11.0 | 11.0 | | 38.0 |
| 40.0 | | | 10.4 | 10.0/41.2m | | 10.6/39.2m | 10.3 | | 40.0 |
| 42.0 | | | 9.7 | 9.7 | | 9.6 | 9.2/43.3m | | 42.0 |
| 44.0 | | | 9.6/42.3m | 9.1 | | 9.0 | 9.0 | | 44.0 |
| 46.0 | | | | 8.6 | | 8.7/45.2m | 8.5 | | 46.0 |
| 48.0 | | | | 8.2 | | | 8.1 | | 48.0 |
| 50.0 | | | | 8.2/47.9m | | | 7.7 | | 50.0 |
| 52.0 | | | | | | | 7.6/50.8m | | 52.0 |

※表中の太線で囲まれた部分は、ブーム等の強度によって定められた値です。

▶タワー長さ 39.7m

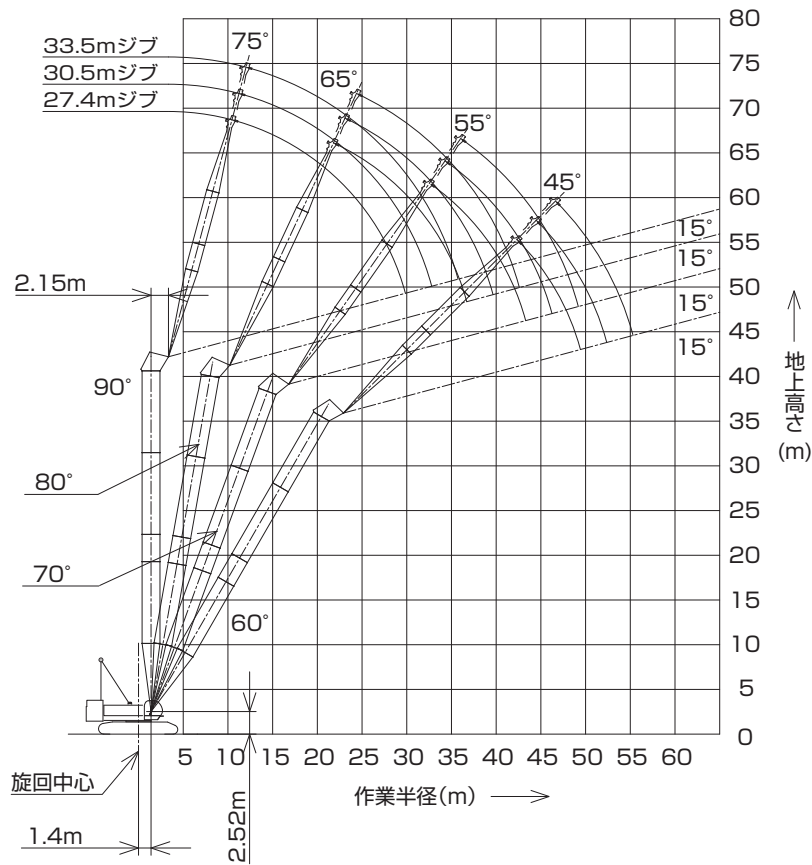

(単位:t)

| タワー長さm | 39.7 | | | | | | | | | | | | タワー長さm |
|----------|------|------------|------------|------------|------------|------------|------------|------------|------------|------------|------------|------|--------|
| ジブ長さm | 27.4 | | | | 30.5 | | | | 33.5 | | | | ジブ長さm |
| タワー角度 | 90° | 80° | 70° | 60° | 90° | 80° | 70° | 60° | 90° | 80° | 70° | 60° | タワー角度 |
| 作業半径 (m) | 10.0 | 25.0/10.9m | | | 25.0/11.7m | | | | | | | | 10.0 |
| | 12.0 | 25.0 | | | 25.0 | | | | 25.0/12.5m | | | | 12.0 |
| | 14.0 | 25.0 | | | 25.0 | | | | 25.0 | | | | 14.0 |
| | 16.0 | 25.0 | | | 25.0 | | | | 24.2 | | | | 16.0 |
| | 18.0 | 25.0 | | | 24.2 | | | | 23.4 | | | | 18.0 |
| | 20.0 | 24.2 | | | 23.5 | | | | 22.6 | | | | 20.0 |
| | 22.0 | 23.2 | 22.8/22.3m | | 22.7 | 21.4/23.6m | | | 21.8 | | | | 22.0 |
| | 24.0 | 20.9 | 20.9 | | 21.0 | 20.9 | | | 21.0 | 20.2/24.8m | | | 24.0 |
| | 26.0 | 18.5 | 18.6 | | 18.6 | 18.6 | | | 18.8 | 18.6 | | | 26.0 |
| | 28.0 | 16.1 | 16.8 | | 16.7 | 16.7 | | | 16.7 | 16.7 | | | 28.0 |
| | 30.0 | 11.2/29.9m | 15.2 | | 15.1 | 15.1 | | | 15.3 | 15.1 | | | 30.0 |
| | 32.0 | | 14.0 | 13.4/33.0m | | 12.0 | 13.9 | | 14.0 | 13.9 | | | 32.0 |
| | 34.0 | | 12.8 | 12.8 | | 10.6/32.8m | 12.7 | 12.4/34.7m | 12.0 | 12.7 | | | 34.0 |
| | 36.0 | | 11.8 | 11.8 | | | 11.7 | 11.7 | 9.2/35.8m | 11.7 | 11.5/36.5m | | 36.0 |
| | 38.0 | | 11.5/36.7m | 11.1 | | | 11.0 | 11.0 | | 11.0 | 11.0 | | 38.0 |
| | 40.0 | | | 10.4 | | | 10.4/39.7m | 10.3 | | 10.2 | 10.3 | | 40.0 |
| | 42.0 | | | 9.7 | 9.5/42.7m | | | 9.6 | | 9.6 | 9.6 | | 42.0 |
| | 44.0 | | | 9.3/43.3m | 9.1 | | | 9.0 | 8.7/44.9m | 9.4/42.6m | 9.0 | | 44.0 |
| 46.0 | | | | 8.6 | | | 8.5 | 8.5 | | 8.4 | 8.2/47.0m | 46.0 | |
| 48.0 | | | | 8.2 | | | 8.4/46.3m | 8.1 | | 8.0 | 8.0 | 48.0 | |
| 50.0 | | | | 8.0/49.4m | | | | 7.7 | | 7.7/49.2m | 7.6 | 50.0 | |
| 52.0 | | | | | | | | 7.3 | | | 7.2 | 52.0 | |
| 54.0 | | | | | | | | 7.2/52.4m | | | 6.8 | 54.0 | |
| 56.0 | | | | | | | | | | | 6.6/55.3m | 56.0 | |

※表中の太線で囲まれた部分は、ブーム等の強度によって定められた値です。

▶タワー長さ 42.7m

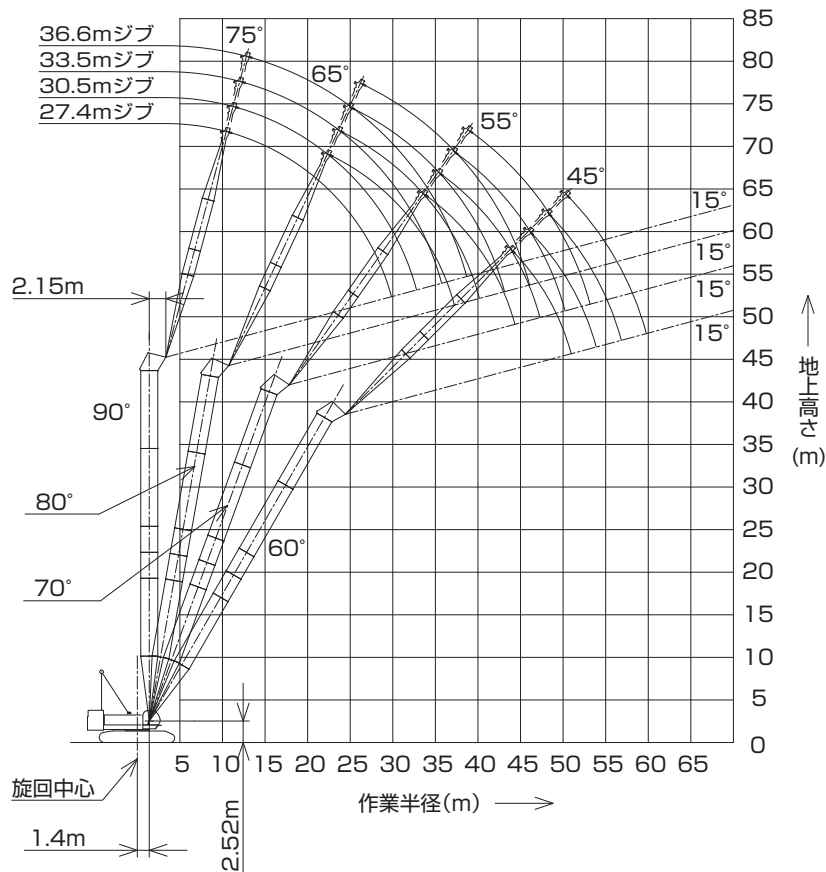

(単位:t)

| タワー長さm | 42.7 | | | | | | | | | | | | | | | | タワー長さm |
|---------|------|------------|------------|------------|------------|------------|------------|-----------|------------|------------|------------|-----------|------------|------------|------------|-----------|--------|
| ジブ長さm | 27.4 | | | | 30.5 | | | | 33.5 | | | | 36.6 | | | | ジブ長さm |
| タワー角度 | 90° | 80° | 70° | 60° | 90° | 80° | 70° | 60° | 90° | 80° | 70° | 60° | 90° | 80° | 70° | 60° | タワー角度 |
| 作業半径(m) | 10.0 | 25.0/10.9m | | | 25.0/11.7m | | | | | | | | | | | | 10.0 |
| | 12.0 | 25.0 | | | 25.0 | | | | 25.0/12.5m | | | | 23.9/13.3m | | | | 12.0 |
| | 14.0 | 25.0 | | | 25.0 | | | | 25.0 | | | | 23.6 | | | | 14.0 |
| | 16.0 | 25.0 | | | 25.0 | | | | 24.2 | | | | 22.9 | | | | 16.0 |
| | 18.0 | 25.0 | | | 24.2 | | | | 23.4 | | | | 22.2 | | | | 18.0 |
| | 20.0 | 24.2 | | | 23.5 | | | | 22.6 | | | | 21.4 | | | | 20.0 |
| | 22.0 | 23.2 | 22.3/22.8m | | 22.7 | | | | 21.8 | | | | 20.7 | | | | 22.0 |
| | 24.0 | 20.9 | 20.9 | | 21.0 | 20.9/24.1m | | | 21.0 | 19.6/25.4m | | | 19.9 | | | | 24.0 |
| | 26.0 | 18.5 | 18.6 | | 18.6 | 18.6 | | | 18.8 | 18.6 | | | 18.8 | 18.2/26.7m | | | 26.0 |
| | 28.0 | 16.3 | 16.8 | | 16.7 | 16.7 | | | 16.7 | 16.7 | | | 16.8 | 16.7 | | | 28.0 |
| | 30.0 | 11.3/29.9m | 15.2 | | 15.1 | 15.1 | | | 15.3 | 15.1 | | | 15.2 | 15.0 | | | 30.0 |
| | 32.0 | | 14.0 | | 12.0 | 13.9 | | | 14.0 | 13.9 | | | 14.0 | 13.8 | | | 32.0 |
| | 34.0 | | 12.8 | 12.8/34.0m | 10.6/32.8m | 12.7 | 11.8/35.8m | | 12.1 | 12.7 | | | 12.8 | 12.6 | | | 34.0 |
| | 36.0 | | 11.8 | 11.8 | | 11.7 | 11.7 | | 9.2/35.8m | 11.7 | | | 11.7 | 11.6 | | | 36.0 |
| | 38.0 | | 11.4/37.3m | 11.1 | | 11.0 | 11.0 | | | 11.0 | 11.0/38.0m | | 9.3 | 10.9 | 10.4/39.3m | | 38.0 |
| | 40.0 | | | 10.4 | | 10.3 | 10.3 | | | 10.2 | 10.3 | | 8.7/38.7m | 10.1 | 10.1 | | 40.0 |
| | 42.0 | | | 9.7 | | 10.2/40.2m | 9.6 | | | 9.6 | 9.6 | | | 9.5 | 9.5 | | 42.0 |
| | 44.0 | | | 9.1 | 9.0/44.2m | | 9.0 | | | 9.3/43.2m | 9.0 | | | 8.9 | 8.9 | | 44.0 |
| | 46.0 | | | 8.9/44.4m | 8.6 | | 8.5 | 8.4/46.4m | | | 8.4 | | | 8.4 | 8.3 | | 46.0 |
| | 48.0 | | | | 8.2 | | 8.2/47.3m | 8.1 | | | 7.9 | 7.9/48.5m | | 8.3/46.1m | 7.8 | | 48.0 |
| 50.0 | | | | 7.8 | | | 7.7 | | | 7.5 | 7.6 | | | 7.4 | 7.3/50.7m | 50.0 | |
| 52.0 | | | | 7.6/51.0m | | | 7.3 | | | | 7.5/50.2m | 7.2 | | 7.0 | 7.1 | 52.0 | |
| 54.0 | | | | | | | 6.9/53.9m | | | | | 6.8 | | | 6.7/53.2m | 6.7 | 54.0 |
| 56.0 | | | | | | | | | | | | 6.4 | | | | 6.3 | 56.0 |
| 58.0 | | | | | | | | | | | | 6.3/56.8m | | | | 6.0 | 58.0 |
| 60.0 | | | | | | | | | | | | | | | | 5.7/59.8m | 60.0 |

※表中の太線で囲まれた部分は、ブーム等の強度によって定められた値です。

▶タワー長さ 45.8m

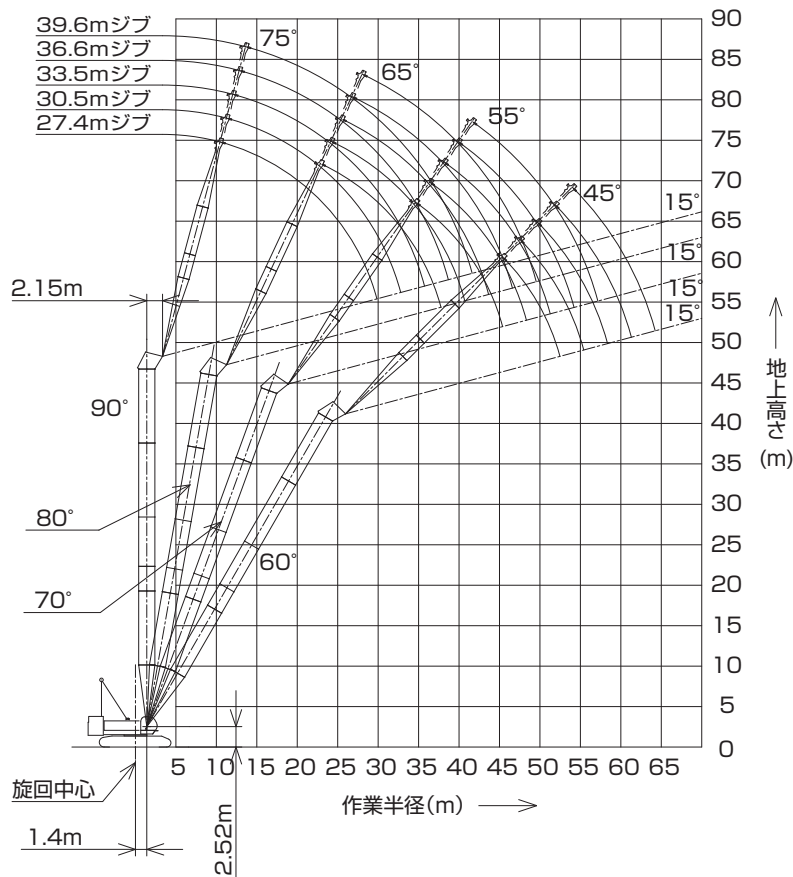

(単位:t)

| タワー長さm | | 45.8 | | | | | | | | | | | | | | | | タワー長さm | | | | | |
|---------|------|------------|------------|------------|-----------|------------|------------|-----------|-----|------------|------------|-----|-----|------------|------------|------------|-----|-----------|------------|------------|-----|-----------|------|
| ジブ長さm | | 27.4 | | | | 30.5 | | | | 33.5 | | | | 36.6 | | | | 39.6 | | | | ジブ長さm | |
| タワー角度 | | 90° | 80° | 70° | 60° | 90° | 80° | 70° | 60° | 90° | 80° | 70° | 60° | 90° | 80° | 70° | 60° | 90° | 80° | 70° | 60° | タワー角度 | |
| 作業半径(m) | 10.0 | 25.0/10.9m | | | | 25.0/11.7m | | | | | | | | | | | | | | | | 10.0 | |
| | 12.0 | 25.0 | | | | 25.0 | | | | 25.0/12.5m | | | | 23.9/13.3m | | | | | | | | 12.0 | |
| | 14.0 | 25.0 | | | | 25.0 | | | | 24.2 | | | | 23.6 | | | | | 22.0/14.1m | | | 14.0 | |
| | 16.0 | 25.0 | | | | 25.0 | | | | 24.2 | | | | 22.9 | | | | | 21.4 | | | 16.0 | |
| | 18.0 | 25.0 | | | | 24.2 | | | | 23.4 | | | | 22.2 | | | | | 20.8 | | | 18.0 | |
| | 20.0 | 24.2 | | | | 23.5 | | | | 22.6 | | | | 21.4 | | | | | 20.2 | | | 20.0 | |
| | 22.0 | 23.2 | 21.7/23.3m | | | 22.7 | | | | 21.8 | | | | 20.7 | | | | | 19.6 | | | 22.0 | |
| | 24.0 | 20.9 | 20.9 | | | 21.0 | 20.3/24.5m | | | 21.0 | 18.7/25.9m | | | 19.9 | | | | | 19.0 | | | 24.0 | |
| | 26.0 | 18.5 | 18.6 | | | 18.6 | 18.6 | | | 18.8 | 18.6 | | | 18.8 | 17.6/27.2m | | | | 18.3 | | | 26.0 | |
| | 28.0 | 16.3 | 16.8 | | | 16.7 | 16.7 | | | 16.7 | 16.7 | | | 16.8 | 16.7 | | | | 16.8 | 16.3/28.5m | | | 28.0 |
| | 30.0 | 11.3/23.9m | 15.2 | | | 15.1 | 15.1 | | | 15.3 | 15.1 | | | 15.2 | 15.0 | | | | 15.2 | 14.9 | | | 30.0 |
| | 32.0 | | 14.0 | | | 12.0 | 13.9 | | | 14.0 | 13.9 | | | 14.0 | 13.8 | | | | 14.0 | 13.7 | | | 32.0 |
| | 34.0 | | 12.8 | 12.3/35.0m | | 10.6/32.8m | 12.7 | | | 12.1 | 12.7 | | | 12.8 | 12.6 | | | | 12.8 | 12.5 | | | 34.0 |
| | 36.0 | | 11.8 | 11.8 | | 11.7 | 11.5/36.8m | | | 9.2/35.8m | 11.7 | | | 11.6 | 11.6 | | | | 11.8 | 11.5 | | | 36.0 |
| | 38.0 | | 11.2/37.9m | 11.1 | | 11.0 | 11.0 | | | 11.0 | 10.9/38.5m | | | 9.3 | 10.9 | | | | 10.8 | 10.8 | | | 38.0 |
| | 40.0 | | | 10.4 | | 10.3 | 10.3 | | | 10.2 | 10.3 | | | 8.7/38.7m | 10.1 | 10.1/40.3m | | | 9.3 | 10.0 | | | 40.0 |
| | 42.0 | | | 9.7 | | | 10.1/40.7m | 9.6 | | | 9.6 | 9.6 | | | 9.5 | 9.5 | | | 7.7/41.7m | 9.4 | | | 42.0 |
| | 44.0 | | | 9.1 | 8.6/45.8m | | 9.0 | | | 9.1/43.7m | 9.0 | | | 8.9 | 8.9 | | | | 8.8 | 8.7 | | | 44.0 |
| | 46.0 | | | 8.8/45.4m | 8.6 | | 8.5 | 8.1/47.9m | | | 8.4 | | | 8.4 | 8.3 | | | | 8.2 | 8.1 | | | 46.0 |
| | 48.0 | | | | 8.2 | | 8.1 | 8.1 | | | 7.9 | | | 8.2/46.6m | 7.8 | | | | 7.6 | 7.6 | | | 48.0 |
| 50.0 | | | | 7.8 | | 8.1/48.3m | 7.7 | | | 7.5 | 7.6/50.1m | | | 7.4 | | | | 7.2/49.6m | 7.2 | | | 50.0 | |
| 52.0 | | | | 7.4 | | | 7.3 | | | 7.3/51.3m | 7.2 | | | 7.0 | 7.0/52.2m | | | | 6.8 | | | 52.0 | |
| 54.0 | | | | 7.3/52.5m | | | 6.9 | | | | 6.8 | | | 6.6 | 6.7 | | | 6.4 | 6.3/54.4m | | | 54.0 | |
| 56.0 | | | | | | | 6.7/55.4m | | | | 6.4 | | | 6.6/54.2m | 6.3 | | | 6.1 | 6.1 | | | 56.0 | |
| 58.0 | | | | | | | | | | | 6.1 | | | | 6.0 | | | 5.9/57.2m | 5.8 | | | 58.0 | |
| 60.0 | | | | | | | | | | | 6.0/58.4m | | | | 5.7 | | | | 5.5 | | | 60.0 | |
| 62.0 | | | | | | | | | | | | | | | 5.5/61.3m | | | | 5.3 | | | 62.0 | |
| 64.0 | | | | | | | | | | | | | | | | | | | 5.1 | | | 64.0 | |
| 66.0 | | | | | | | | | | | | | | | | | | | | | | 5.0/64.3m | 66.0 |

※表中の太線で囲まれた部分は、ブーム等の強度によって定められた値です。

▶タワー長さ 48.8m

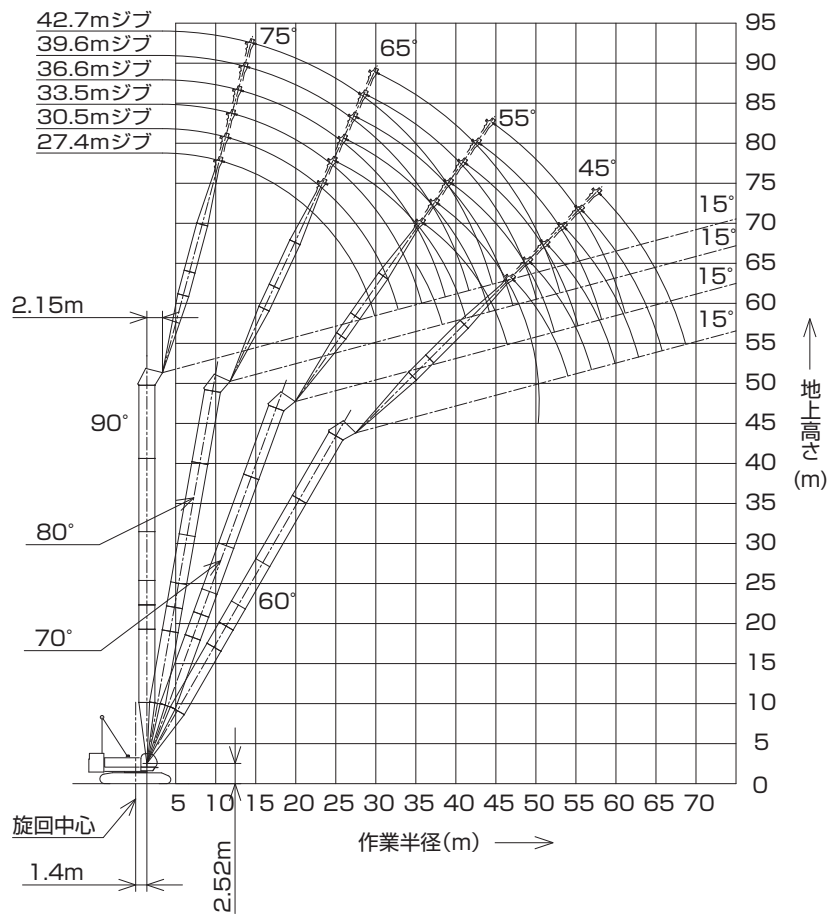

(単位:t)

| タワー長さm | 48.8 | | | | | | | | タワー長さm |
|----------|-----------|------------|-----|-----|------------|-----------|------------|------|--------|
| ジブ長さm | 27.4 | | | | 30.5 | | | | ジブ長さm |
| タワー角度 | 90° | 80° | 70° | 60° | 90° | 80° | 70° | 60° | タワー角度 |
| 作業半径 (m) | 10.0 | 25.0/10.9m | | | 25.0/11.7m | | | | 10.0 |
| | 12.0 | 25.0 | | | 25.0 | | | | 12.0 |
| | 14.0 | 25.0 | | | 25.0 | | | | 14.0 |
| | 16.0 | 25.0 | | | 25.0 | | | | 16.0 |
| | 18.0 | 25.0 | | | 24.2 | | | | 18.0 |
| | 20.0 | 24.2 | | | 23.5 | | | | 20.0 |
| | 22.0 | 23.2 | | | 22.7 | | | | 22.0 |
| | 24.0 | 20.9 | | | 21.2/23.9m | | 21.0 | | 24.0 |
| | 26.0 | 18.5 | | | 20.9 | | 19.7/25.1m | | 26.0 |
| | 28.0 | 16.3 | | | 18.6 | | 18.6 | | 28.0 |
| | 30.0 | 11.3/29.9m | | | 16.8 | | 16.7 | | 30.0 |
| | 32.0 | 14.0 | | | 15.2 | | 15.1 | | 32.0 |
| | 34.0 | 12.8 | | | 12.0 | | 13.9 | | 34.0 |
| | 36.0 | 11.8 | | | 10.6/32.8m | | 12.7 | | 36.0 |
| | 38.0 | 11.1 | | | 11.8/36.1m | | 11.7 | | 38.0 |
| | 40.0 | 11.0/38.3m | | | 11.1 | | 11.0 | | 40.0 |
| | 42.0 | 9.7 | | | 10.4 | | 10.3 | | 42.0 |
| | 44.0 | 9.1 | | | 9.7 | | 9.9/41.3m | | 44.0 |
| | 46.0 | 8.6 | | | 9.1 | | 9.0 | | 46.0 |
| | 48.0 | 8.5/46.4m | | | 8.6 | | 8.3/47.3m | | 48.0 |
| 50.0 | 7.8 | | | 8.2 | | 8.0 | | 50.0 | |
| 52.0 | 7.4 | | | 7.8 | | 7.7/49.4m | | 52.0 | |
| 54.0 | 7.0/54.0m | | | 7.4 | | 7.3 | | 54.0 | |
| 56.0 | 6.5 | | | 6.9 | | 6.5 | | 56.0 | |
| 58.0 | 6.4/56.9m | | | 6.5 | | 6.4/56.9m | | 58.0 | |

※表中の太線で囲まれた部分は、ブーム等の強度によって定められた値です。

(単位:t)

| タワー長さm | 48.8 | | | | | | | | タワー長さm |
|--------|------------|------------|------------|-----------|------------|------------|-----------|-----------|--------|
| ジブ長さm | 33.5 | | | | 36.6 | | | | ジブ長さm |
| タワー角度 | 90° | 80° | 70° | 60° | 90° | 80° | 70° | 60° | タワー角度 |
| 12.0 | 25.0/12.5m | | | | 23.9/13.3m | | | | 12.0 |
| 14.0 | 25.0 | | | | 23.6 | | | | 14.0 |
| 16.0 | 24.2 | | | | 22.9 | | | | 16.0 |
| 18.0 | 23.4 | | | | 22.2 | | | | 18.0 |
| 20.0 | 22.6 | | | | 21.4 | | | | 20.0 |
| 22.0 | 21.8 | | | | 20.7 | | | | 22.0 |
| 24.0 | 21.0 | | | | 19.9 | | | | 24.0 |
| 26.0 | 18.8 | 18.4/26.4m | | | 18.8 | 17.0/27.7m | | | 26.0 |
| 28.0 | 16.7 | 16.7 | | | 16.8 | 16.7 | | | 28.0 |
| 30.0 | 15.3 | 15.1 | | | 15.2 | 15.0 | | | 30.0 |
| 32.0 | 14.0 | 13.9 | | | 14.0 | 13.8 | | | 32.0 |
| 34.0 | 12.1 | 12.7 | | | 12.8 | 12.6 | | | 34.0 |
| 36.0 | 9.2/35.8m | 11.7 | | | 11.6 | 11.6 | | | 36.0 |
| 38.0 | | 11.0 | 10.3/39.6m | | 9.3 | 10.9 | | | 38.0 |
| 40.0 | | 10.2 | 10.2 | | 8.7/38.7m | 10.1 | 9.6/41.3m | | 40.0 |
| 42.0 | | 9.6 | 9.5 | | | 9.5 | 9.4 | | 42.0 |
| 44.0 | | 8.9 | 8.9 | | | 8.9 | 8.8 | | 44.0 |
| 46.0 | | 8.9/44.2m | 8.4 | | | 8.4 | 8.3 | | 46.0 |
| 48.0 | | | 7.9 | | | 8.1/47.2m | 7.8 | | 48.0 |
| 50.0 | | | 7.5 | 7.3/51.6m | | | 7.4 | | 50.0 |
| 52.0 | | | 7.1 | 7.2 | | | 7.0 | 6.8/53.7m | 52.0 |
| 54.0 | | | 7.1/52.3m | 6.8 | | | 6.6 | 6.7 | 54.0 |
| 56.0 | | | | 6.4 | | | 6.4/55.3m | 6.3 | 56.0 |
| 58.0 | | | | 6.1 | | | | 6.0 | 58.0 |
| 60.0 | | | | 5.8/59.9m | | | | 5.7 | 60.0 |
| 62.0 | | | | | | | | 5.4 | 62.0 |
| 64.0 | | | | | | | | 5.3/62.8m | 64.0 |

※表中の太線で囲まれた部分は、ブーム等の強度によって定められた値です。

(単位:t)

| タワー長さm | 48.8 | | | | | | | | タワー長さm |
|--------|------------|------------|-----------|-----------|------------|------------|-----------|-----------|--------|
| ジブ長さm | 39.6 | | | | 42.7 | | | | ジブ長さm |
| タワー角度 | 90° | 80° | 70° | 60° | 90° | 80° | 70° | 60° | タワー角度 |
| 14.0 | 22.0/14.1m | | | | 20.0/14.9m | | | | 14.0 |
| 16.0 | 21.4 | | | | 19.7 | | | | 16.0 |
| 18.0 | 20.8 | | | | 19.2 | | | | 18.0 |
| 20.0 | 20.2 | | | | 18.6 | | | | 20.0 |
| 22.0 | 19.6 | | | | 18.1 | | | | 22.0 |
| 24.0 | 19.0 | | | | 17.5 | | | | 24.0 |
| 26.0 | 18.3 | | | | 17.0 | | | | 26.0 |
| 28.0 | 16.8 | 15.8/29.0m | | | 16.5 | | | | 28.0 |
| 30.0 | 15.2 | 14.9 | | | 15.2 | 14.7/30.3m | | | 30.0 |
| 32.0 | 14.0 | 13.7 | | | 14.0 | 13.6 | | | 32.0 |
| 34.0 | 12.8 | 12.5 | | | 12.8 | 12.4 | | | 34.0 |
| 36.0 | 11.8 | 11.5 | | | 11.8 | 11.4 | | | 36.0 |
| 38.0 | 10.8 | 10.8 | | | 10.9 | 10.6 | | | 38.0 |
| 40.0 | 9.3 | 10.0 | | | 9.8 | 9.8 | | | 40.0 |
| 42.0 | 7.7/41.7m | 9.4 | 9.0/43.1m | | 8.9 | 9.2 | | | 42.0 |
| 44.0 | | 8.8 | 8.7 | | 7.2 | 8.6 | 8.3/44.8m | | 44.0 |
| 46.0 | | 8.2 | 8.1 | | 6.8/44.6m | 8.0 | 7.9 | | 46.0 |
| 48.0 | | 7.6 | 7.6 | | | 7.4 | 7.4 | | 48.0 |
| 50.0 | | 7.2 | 7.2 | | | 7.0 | 7.0 | | 50.0 |
| 52.0 | | 7.1/50.1m | 6.8 | | | 6.6 | 6.6 | | 52.0 |
| 54.0 | | | 6.4 | 6.1/55.9m | | 6.4/53.0m | 6.2 | | 54.0 |
| 56.0 | | | 6.1 | 6.1 | | | 5.9 | | 56.0 |
| 58.0 | | | 5.8 | 5.8 | | | 5.6 | 5.6/58.1m | 58.0 |
| 60.0 | | | 5.8/58.2m | 5.5 | | | 5.4 | 5.4 | 60.0 |
| 62.0 | | | | 5.3 | | | 5.3/61.2m | 5.2 | 62.0 |
| 64.0 | | | | 5.1 | | | | 5.0 | 64.0 |
| 66.0 | | | | 4.9/65.8m | | | | 4.8 | 66.0 |
| 68.0 | | | | | | | | 4.6 | 68.0 |
| 70.0 | | | | | | | | 4.5/68.7m | 70.0 |

※表中の太線で囲まれた部分は、ブーム等の強度によって定められた値です。

▶タワー長さ 51.9m

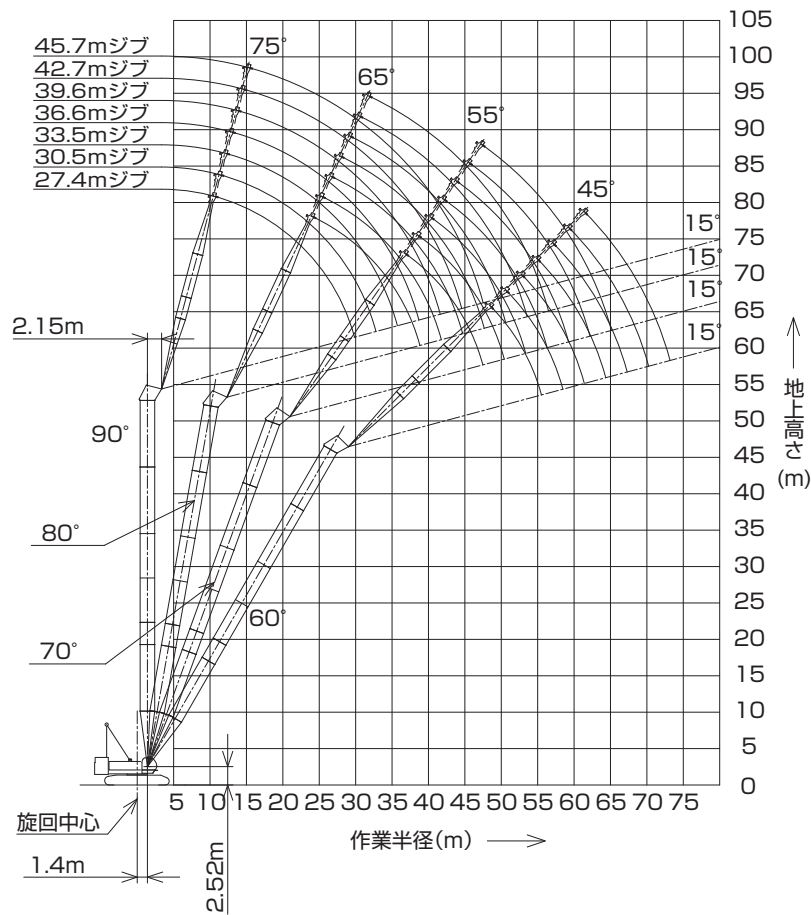

(単位:t)

| タワー長さm | 51.9 | | | | | | | | | | | | タワー長さm |
|--------|------------|------------|------------|-----------|------------|------------|------------|-----------|------------|------------|------------|-----------|--------|
| ジブ長さm | 27.4 | | | | 30.5 | | | | 33.5 | | | | ジブ長さm |
| タワー角度 | 90° | 80° | 70° | 60° | 90° | 80° | 70° | 60° | 90° | 80° | 70° | 60° | タワー角度 |
| 10.0 | 25.0/10.9m | | | | 25.0/11.7m | | | | | | | | 10.0 |
| 12.0 | 25.0 | | | | 25.0 | | | | 25.0/12.5m | | | | 12.0 |
| 14.0 | 25.0 | | | | 25.0 | | | | 25.0 | | | | 14.0 |
| 16.0 | 25.0 | | | | 25.0 | | | | 24.2 | | | | 16.0 |
| 18.0 | 25.0 | | | | 24.2 | | | | 23.4 | | | | 18.0 |
| 20.0 | 24.2 | | | | 23.5 | | | | 22.6 | | | | 20.0 |
| 22.0 | 23.2 | | | | 22.7 | | | | 21.8 | | | | 22.0 |
| 24.0 | 20.9 | 20.6/24.4m | | | 21.0 | 19.0/25.7m | | | 21.0 | | | | 24.0 |
| 26.0 | 18.5 | 18.6 | | | 18.6 | 18.6 | | | 18.8 | 17.8/27.0m | | | 26.0 |
| 28.0 | 16.3 | 16.8 | | | 16.7 | 16.7 | | | 16.7 | 16.7 | | | 28.0 |
| 30.0 | 11.3/29.9m | 15.2 | | | 15.1 | 15.1 | | | 15.3 | 15.1 | | | 30.0 |
| 32.0 | | 14.0 | | | 12.0 | 13.9 | | | 14.0 | 13.9 | | | 32.0 |
| 34.0 | | 12.8 | | | 10.6/32.8m | 12.7 | | | 12.1 | 12.7 | | | 34.0 |
| 36.0 | | 11.8 | 11.4/37.1m | | | 11.7 | | | 9.2/35.8m | 11.7 | | | 36.0 |
| 38.0 | | 11.1 | 11.1 | | | 11.0 | 10.7/38.9m | | | 11.0 | | | 38.0 |
| 40.0 | | 10.8/38.9m | 10.4 | | | 10.3 | 10.3 | | | 10.2 | 10.0/40.6m | | 40.0 |
| 42.0 | | | 9.7 | | | 9.7/41.8m | 9.6 | | | 9.6 | 9.5 | | 42.0 |
| 44.0 | | | 9.1 | | | | 9.0 | | | 8.9 | 8.9 | | 44.0 |
| 46.0 | | | 8.6 | | | | 8.5 | | | 8.8/44.7m | 8.4 | | 46.0 |
| 48.0 | | | 8.2/47.5m | 8.0/48.8m | | | 8.0 | | | | 7.9 | | 48.0 |
| 50.0 | | | | 7.8 | | | 7.6 | 7.5/51.0m | | | 7.5 | | 50.0 |
| 52.0 | | | | 7.4 | | | 7.5/50.4m | 7.3 | | | 7.1 | 7.0/53.1m | 52.0 |
| 54.0 | | | | 7.0 | | | | 6.9 | | | 6.9/53.4m | 6.8 | 54.0 |
| 56.0 | | | | 6.7/55.5m | | | | 6.5 | | | | 6.4 | 56.0 |
| 58.0 | | | | | | | | 6.2 | | | | 6.1 | 58.0 |
| 60.0 | | | | | | | | 6.1/58.5m | | | | 5.8 | 60.0 |
| 62.0 | | | | | | | | | | | | 5.6/61.4m | 62.0 |

※表中の太線で囲まれた部分は、ブーム等の強度によって定められた値です。

(単位:t)

| タワー長さm | 51.9 | | | | | | | | タワー長さm |
|--------|------------|------------|-----------|-----------|------------|------------|-----------|-----------|--------|
| ジブ長さm | 36.6 | | | | 39.6 | | | | ジブ長さm |
| タワー角度 | 90° | 80° | 70° | 60° | 90° | 80° | 70° | 60° | タワー角度 |
| 12.0 | 23.9/13.3m | | | | | | | | 12.0 |
| 14.0 | 23.6 | | | | 22.0/14.1m | | | | 14.0 |
| 16.0 | 22.9 | | | | 21.4 | | | | 16.0 |
| 18.0 | 22.2 | | | | 20.8 | | | | 18.0 |
| 20.0 | 21.4 | | | | 20.2 | | | | 20.0 |
| 22.0 | 20.7 | | | | 19.6 | | | | 22.0 |
| 24.0 | 19.9 | | | | 19.0 | | | | 24.0 |
| 26.0 | 18.8 | | | | 18.3 | | | | 26.0 |
| 28.0 | 16.8 | 16.6/28.2m | | | 16.8 | 15.4/29.5m | | | 28.0 |
| 30.0 | 15.2 | 15.0 | | | 15.2 | 14.9 | | | 30.0 |
| 32.0 | 14.0 | 13.8 | | | 14.0 | 13.7 | | | 32.0 |
| 34.0 | 12.8 | 12.6 | | | 12.8 | 12.5 | | | 34.0 |
| 36.0 | 11.6 | 11.6 | | | 11.8 | 11.5 | | | 36.0 |
| 38.0 | 9.3 | 10.9 | | | 10.8 | 10.8 | | | 38.0 |
| 40.0 | 8.7/38.7m | 10.1 | | | 9.3 | 10.0 | | | 40.0 |
| 42.0 | | 9.5 | 9.3/42.4m | | 7.7/41.7m | 9.4 | | | 42.0 |
| 44.0 | | 8.9 | 8.8 | | | 8.8 | 8.7/44.1m | | 44.0 |
| 46.0 | | 8.4 | 8.3 | | | 8.2 | 8.1 | | 46.0 |
| 48.0 | | 7.9/47.7m | 7.8 | | | 7.6 | 7.6 | | 48.0 |
| 50.0 | | | 7.4 | | | 7.2 | 7.2 | | 50.0 |
| 52.0 | | | 7.0 | | | 7.1/50.6m | 6.8 | | 52.0 |
| 54.0 | | | 6.6 | 6.4/55.3m | | | 6.4 | | 54.0 |
| 56.0 | | | 6.3 | 6.3 | | | 6.1 | 5.9/57.4m | 56.0 |
| 58.0 | | | 6.3/56.3m | 6.0 | | | 5.8 | 5.8 | 58.0 |
| 60.0 | | | | 5.7 | | | 5.6/59.3m | 5.5 | 60.0 |
| 62.0 | | | | 5.4 | | | | 5.2 | 62.0 |
| 64.0 | | | | 5.2 | | | | 5.0 | 64.0 |
| 66.0 | | | | 5.1/64.4m | | | | 4.8 | 66.0 |
| 68.0 | | | | | | | | 4.6/67.3m | 68.0 |

※表中の太線で囲まれた部分は、ブーム等の強度によって定められた値です。

(単位:t)

| タワー長さm | 51.9 | | | | | | | | タワー長さm |
|--------|------------|------------|-----------|-----------|------------|------------|-----------|-----------|--------|
| ジブ長さm | 42.7 | | | | 45.7 | | | | ジブ長さm |
| タワー角度 | 90° | 80° | 70° | 60° | 90° | 80° | 70° | 60° | タワー角度 |
| 14.0 | 20.0/14.9m | | | | 17.4/15.7m | | | | 14.0 |
| 16.0 | 19.7 | | | | 17.4 | | | | 16.0 |
| 18.0 | 19.2 | | | | 16.9 | | | | 18.0 |
| 20.0 | 18.6 | | | | 16.4 | | | | 20.0 |
| 22.0 | 18.1 | | | | 16.0 | | | | 22.0 |
| 24.0 | 17.5 | | | | 15.5 | | | | 24.0 |
| 26.0 | 17.0 | | | | 15.0 | | | | 26.0 |
| 28.0 | 16.5 | | | | 14.6 | | | | 28.0 |
| 30.0 | 15.2 | 14.4/30.8m | | | 14.1 | | | | 30.0 |
| 32.0 | 14.0 | 13.6 | | | 13.6 | 13.4/32.1m | | | 32.0 |
| 34.0 | 12.8 | 12.4 | | | 12.6 | 12.3 | | | 34.0 |
| 36.0 | 11.8 | 11.4 | | | 11.6 | 11.3 | | | 36.0 |
| 38.0 | 10.8 | 10.6 | | | 10.6 | 10.5 | | | 38.0 |
| 40.0 | 9.8 | 9.8 | | | 9.7 | 9.7 | | | 40.0 |
| 42.0 | 8.9 | 9.2 | | | 8.9 | 9.0 | | | 42.0 |
| 44.0 | 7.2 | 8.6 | 7.9/45.9m | | 8.1 | 8.4 | | | 44.0 |
| 46.0 | 6.8/44.6m | 8.0 | 7.9 | | 7.1 | 7.8 | 7.4/47.6m | | 46.0 |
| 48.0 | | 7.4 | 7.4 | | 6.1/47.5m | 7.2 | 7.3 | | 48.0 |
| 50.0 | | 7.0 | 7.0 | | | 6.8 | 6.8 | | 50.0 |
| 52.0 | | 6.6 | 6.6 | | | 6.4 | 6.4 | | 52.0 |
| 54.0 | | 6.2/53.6m | 6.2 | | | 6.0 | 6.0 | | 54.0 |
| 56.0 | | | 5.9 | | | 5.7 | 5.7 | | 56.0 |
| 58.0 | | | 5.6 | 5.3/59.6m | | 5.6/56.5m | 5.4 | | 58.0 |
| 60.0 | | | 5.4 | 5.3 | | | 5.2 | 4.8/61.7m | 60.0 |
| 62.0 | | | 5.2 | 5.0 | | | 5.0 | 4.8 | 62.0 |
| 64.0 | | | 5.2/62.2m | 4.8 | | | 4.8 | 4.6 | 64.0 |
| 66.0 | | | | 4.6 | | | 4.6/65.2m | 4.4 | 66.0 |
| 68.0 | | | | 4.4 | | | | 4.2 | 68.0 |
| 70.0 | | | | 4.2 | | | | 4.0 | 70.0 |
| 72.0 | | | | 4.2/70.2m | | | | 3.8 | 72.0 |
| 74.0 | | | | | | | | 3.7/73.2m | 74.0 |

※表中の太線で囲まれた部分は、ブーム等の強度によって定められた値です。

▶タワー長さ 54.9m

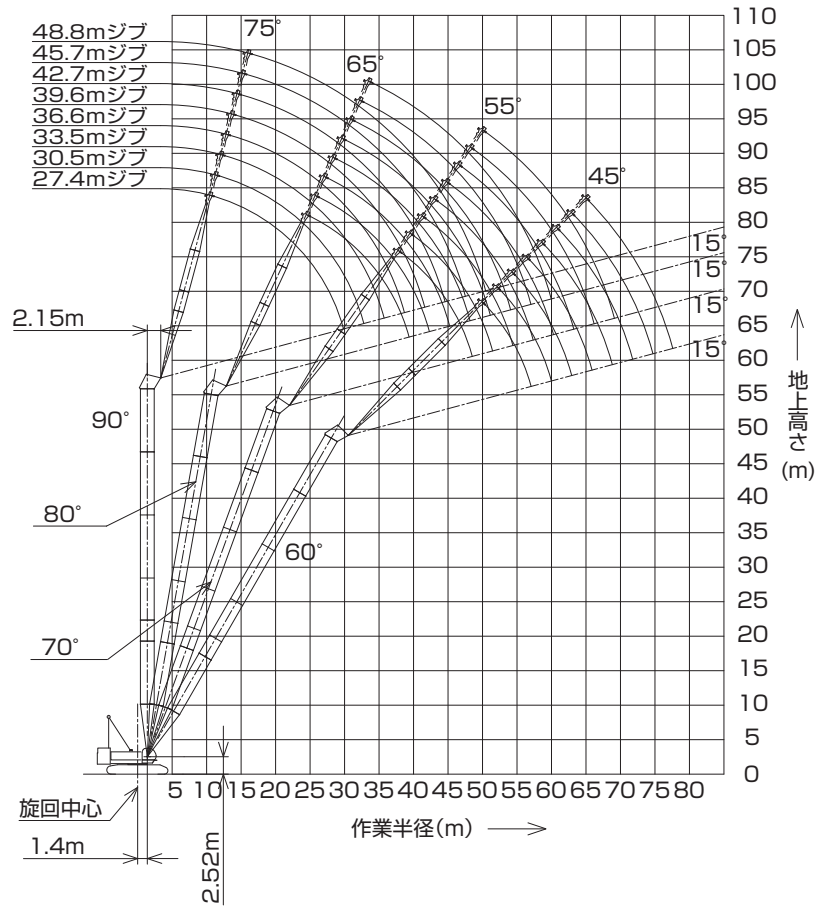

(単位:t)

| タワー長さm | 54.9 | | | | | | | | | | | | タワー長さm |
|----------|------|------------|------------|------------|------------|------------|------------|-----|------------|------------|-----------|------|--------|
| ジブ長さm | 27.4 | | | | 30.5 | | | | 33.5 | | | | ジブ長さm |
| タワー角度 | 90° | 80° | 70° | 60° | 90° | 80° | 70° | 60° | 90° | 80° | 70° | 60° | タワー角度 |
| 作業半径 (m) | 10.0 | 25.0/10.9m | | | 25.0/11.7m | | | | 25.0/12.5m | | | | 10.0 |
| | 12.0 | 25.0 | | | 25.0 | | | | 25.0 | | | | 12.0 |
| | 14.0 | 25.0 | | | 25.0 | | | | 25.0 | | | | 14.0 |
| | 16.0 | 25.0 | | | 25.0 | | | | 24.2 | | | | 16.0 |
| | 18.0 | 25.0 | | | 24.2 | | | | 23.4 | | | | 18.0 |
| | 20.0 | 24.2 | | | 23.5 | | | | 22.6 | | | | 20.0 |
| | 22.0 | 23.2 | | | 22.7 | | | | 21.7 | | | | 22.0 |
| | 24.0 | 20.9 | 20.0/24.9m | | 21.0 | | | | 21.0 | | | | 24.0 |
| | 26.0 | 18.5 | 18.6 | | 18.6 | 18.6/26.2m | | | 18.8 | 17.2/27.5m | | | 26.0 |
| | 28.0 | 16.3 | 16.8 | | 16.7 | 16.7 | | | 16.7 | 16.7 | | | 28.0 |
| | 30.0 | 11.3/29.9m | 15.2 | | 15.1 | 15.1 | | | 15.3 | 15.1 | | | 30.0 |
| | 32.0 | | 14.0 | | 12.0 | 13.9 | | | 14.0 | 13.9 | | | 32.0 |
| | 34.0 | | 12.8 | | 10.6/32.8m | 12.7 | | | 12.2 | 12.7 | | | 34.0 |
| | 36.0 | | 11.8 | | | 11.7 | | | 9.3/35.8m | 11.7 | | | 36.0 |
| | 38.0 | | 11.1 | 11.0/38.2m | | 11.0 | 10.3/39.9m | | | 11.0 | | | 38.0 |
| | 40.0 | | 10.6/39.4m | 10.4 | | 10.3 | 10.3 | | | 10.2 | 9.6/41.7m | | 40.0 |
| | 42.0 | | | 9.7 | | 9.5 | 9.6 | | | 9.6 | 9.5 | | 42.0 |
| | 44.0 | | | 9.1 | | 9.5/42.3m | 9.0 | | | 8.9 | 8.9 | | 44.0 |
| | 46.0 | | | 8.6 | | | 8.5 | | | 8.6/45.3m | 8.4 | | 46.0 |
| | 48.0 | | | 8.2 | | | 8.0 | | | | 7.9 | | 48.0 |
| 50.0 | | | 8.1/48.5m | 7.7/50.3m | | 7.6 | | | 7.5 | | | 50.0 | |
| 52.0 | | | | 7.4 | | 7.3/51.5m | 7.2/52.5m | | 7.1 | | | 52.0 | |
| 54.0 | | | | 7.0 | | | 6.9 | | 6.8 | 6.7/54.6m | | 54.0 | |
| 56.0 | | | | 6.6 | | | 6.5 | | 6.7/54.4m | 6.4 | | 56.0 | |
| 58.0 | | | | 6.4/57.0m | | | 6.1 | | | 6.0 | | 58.0 | |
| 60.0 | | | | | | | 5.8/60.0m | | | 5.7 | | 60.0 | |
| 62.0 | | | | | | | | | | 5.4 | | 62.0 | |
| 64.0 | | | | | | | | | | 5.3/62.9m | | 64.0 | |

※表中の太線で囲まれた部分は、ブーム等の強度によって定められた値です。

(単位:t)

| タワー長さm | 54.9 | | | | | | | | | | | | タワー長さm |
|--------|------------|------------|-----------|-----------|------------|------------|-----------|-----------|------------|------------|-----------|-----------|--------|
| ジブ長さm | 36.6 | | | | 39.6 | | | | 42.7 | | | | ジブ長さm |
| タワー角度 | 90° | 80° | 70° | 60° | 90° | 80° | 70° | 60° | 90° | 80° | 70° | 60° | タワー角度 |
| 12.0 | 23.9/13.3m | | | | | | | | | | | | 12.0 |
| 14.0 | 23.6 | | | | 22.0/14.1m | | | | 20.0/14.9m | | | | 14.0 |
| 16.0 | 22.9 | | | | 21.4 | | | | 19.7 | | | | 16.0 |
| 18.0 | 22.2 | | | | 20.8 | | | | 19.2 | | | | 18.0 |
| 20.0 | 21.4 | | | | 20.2 | | | | 18.6 | | | | 20.0 |
| 22.0 | 20.7 | | | | 19.6 | | | | 18.1 | | | | 22.0 |
| 24.0 | 19.9 | | | | 19.0 | | | | 17.5 | | | | 24.0 |
| 26.0 | 18.8 | | | | 18.3 | | | | 17.0 | | | | 26.0 |
| 28.0 | 16.8 | 16.2/28.8m | | | 16.8 | | | | 16.5 | | | | 28.0 |
| 30.0 | 15.2 | 15.0 | | | 15.2 | 14.9/30.1m | | | 15.2 | 14.1/31.4m | | | 30.0 |
| 32.0 | 14.0 | 13.8 | | | 14.0 | 13.7 | | | 14.0 | 13.6 | | | 32.0 |
| 34.0 | 12.8 | 12.6 | | | 12.8 | 12.5 | | | 12.8 | 12.4 | | | 34.0 |
| 36.0 | 11.6 | 11.6 | | | 11.8 | 11.5 | | | 11.8 | 11.4 | | | 36.0 |
| 38.0 | 9.3 | 10.9 | | | 10.8 | 10.8 | | | 10.8 | 10.6 | | | 38.0 |
| 40.0 | 8.7/38.7m | 10.1 | | | 9.5 | 10.0 | | | 9.8 | 9.8 | | | 40.0 |
| 42.0 | | 9.5 | 9.0/43.4m | | 7.9/41.7m | 9.4 | | | 8.8 | 9.2 | | | 42.0 |
| 44.0 | | 8.9 | 8.8 | | | 8.8 | 8.3/45.2m | | 7.3 | 8.6 | | | 44.0 |
| 46.0 | | 8.4 | 8.3 | | | 8.2 | 8.1 | | 6.9/44.6m | 8.0 | 7.7/46.9m | | 46.0 |
| 48.0 | | 7.8 | 7.8 | | | 7.6 | 7.6 | | | 7.4 | 7.4 | | 48.0 |
| 50.0 | | 7.8/48.2m | 7.4 | | | 7.2 | 7.2 | | | 7.0 | 7.0 | | 50.0 |
| 52.0 | | | 7.0 | | | 6.9/51.2m | 6.8 | | | 6.6 | 6.6 | | 52.0 |
| 54.0 | | | 6.6 | | | | 6.4 | | | 6.2 | 6.2 | | 54.0 |
| 56.0 | | | 6.3 | 6.1/56.8m | | | 6.1 | | | 6.2/54.1m | 5.9 | | 56.0 |
| 58.0 | | | 6.0/57.4m | 5.9 | | | 5.8 | 5.7/58.9m | | | 5.6 | | 58.0 |
| 60.0 | | | | 5.6 | | | 5.6 | 5.5 | | | 5.4 | 5.1/61.1m | 60.0 |
| 62.0 | | | | 5.3 | | | 5.6/60.3m | 5.3 | | | 5.2 | 5.0 | 62.0 |
| 64.0 | | | | 5.1 | | | | 5.0 | | | 5.0/63.3m | 4.8 | 64.0 |
| 66.0 | | | | 4.9/65.9m | | | | 4.8 | | | | 4.6 | 66.0 |
| 68.0 | | | | | | | | 4.6 | | | | 4.4 | 68.0 |
| 70.0 | | | | | | | | 4.5/68.8m | | | | 4.2 | 70.0 |
| 72.0 | | | | | | | | | | | | 4.0/71.8m | 72.0 |

※表中の太線で囲まれた部分は、ブーム等の強度によって定められた値です。

(単位:t)

| タワー長さm | 54.9 | | | | | | | | タワー長さm |
|--------|------------|------------|-----------|-----------|------------|------------|-----------|-----------|--------|
| ジブ長さm | 45.7 | | | | 48.8 | | | | ジブ長さm |
| タワー角度 | 90° | 80° | 70° | 60° | 90° | 80° | 70° | 60° | タワー角度 |
| 14.0 | 17.4/15.7m | | | | | | | | 14.0 |
| 16.0 | 17.4 | | | | 15.4/16.5m | | | | 16.0 |
| 18.0 | 16.9 | | | | 15.0 | | | | 18.0 |
| 20.0 | 16.4 | | | | 14.6 | | | | 20.0 |
| 22.0 | 16.0 | | | | 14.2 | | | | 22.0 |
| 24.0 | 15.5 | | | | 13.7 | | | | 24.0 |
| 26.0 | 15.0 | | | | 13.3 | | | | 26.0 |
| 28.0 | 14.6 | | | | 12.9 | | | | 28.0 |
| 30.0 | 14.1 | | | | 12.5 | | | | 30.0 |
| 32.0 | 13.6 | 13.4/32.6m | | | 12.0 | 12.1/33.9m | | | 32.0 |
| 34.0 | 12.6 | 12.3 | | | 11.6 | 12.1 | | | 34.0 |
| 36.0 | 11.6 | 11.3 | | | 10.9 | 11.1 | | | 36.0 |
| 38.0 | 10.6 | 10.5 | | | 10.1 | 10.2 | | | 38.0 |
| 40.0 | 9.7 | 9.7 | | | 9.4 | 9.4 | | | 40.0 |
| 42.0 | 8.8 | 9.0 | | | 8.6 | 8.7 | | | 42.0 |
| 44.0 | 8.1 | 8.4 | | | 7.9 | 8.1 | | | 44.0 |
| 46.0 | 7.1 | 7.8 | | | 7.3 | 7.6 | | | 46.0 |
| 48.0 | 6.1/47.5m | 7.2 | 7.1/48.7m | | 6.6 | 7.0 | | | 48.0 |
| 50.0 | | 6.8 | 6.8 | | 5.6 | 6.6 | 6.5/50.4m | | 50.0 |
| 52.0 | | 6.4 | 6.4 | | 5.3/50.5m | 6.2 | 6.2 | | 52.0 |
| 54.0 | | 6.0 | 6.0 | | | 5.8 | 5.8 | | 54.0 |
| 56.0 | | 5.7 | 5.7 | | | 5.5 | 5.5 | | 56.0 |
| 58.0 | | 5.5/57.0m | 5.4 | | | 5.2 | 5.2 | | 58.0 |
| 60.0 | | | 5.2 | | | 5.0/60.0m | 5.0 | | 60.0 |
| 62.0 | | | 5.0 | 4.7/63.3m | | | 4.8 | | 62.0 |
| 64.0 | | | 4.8 | 4.6 | | | 4.6 | 4.3/65.4m | 64.0 |
| 66.0 | | | 4.6 | 4.4 | | | 4.4 | 4.2 | 66.0 |
| 68.0 | | | 4.6/66.2m | 4.2 | | | 4.2 | 4.0 | 68.0 |
| 70.0 | | | | 4.0 | | | 4.1/69.1m | 3.8 | 70.0 |
| 72.0 | | | | 3.8 | | | | 3.6 | 72.0 |
| 74.0 | | | | 3.6 | | | | 3.4 | 74.0 |
| 76.0 | | | | 3.5/74.7m | | | | 3.2 | 76.0 |
| 78.0 | | | | | | | | 3.0/77.7m | 78.0 |

※表中の太線で囲まれた部分は、ブーム等の強度によって定められた値です。

(単位:t)

| タワー長さm | | 58.0 | | | | | | | | | | | | タワー長さm |
|---------|------|------------|------------|-----------|-----------|------------|------------|-----------|-----------|------------|------------|-----------|------|--------|
| ジブ長さm | | 36.6 | | | | 39.6 | | | | 42.7 | | | | ジブ長さm |
| タワー角度 | | 90° | 80° | 70° | 60° | 90° | 80° | 70° | 60° | 90° | 80° | 70° | 60° | タワー角度 |
| 作業半径(m) | 12.0 | 23.9/13.3m | | | | | | | | | | | | 12.0 |
| | 14.0 | 23.6 | | | | 22.0/14.1m | | | | 20.0/14.9m | | | | 14.0 |
| | 16.0 | 22.9 | | | | 21.4 | | | | 19.7 | | | | 16.0 |
| | 18.0 | 22.2 | | | | 20.8 | | | | 19.2 | | | | 18.0 |
| | 20.0 | 21.4 | | | | 20.2 | | | | 18.6 | | | | 20.0 |
| | 22.0 | 20.7 | | | | 19.6 | | | | 18.1 | | | | 22.0 |
| | 24.0 | 19.9 | | | | 19.0 | | | | 17.5 | | | | 24.0 |
| | 26.0 | 18.8 | | | | 18.3 | | | | 17.0 | | | | 26.0 |
| | 28.0 | 16.8 | 15.7/29.3m | | | 16.8 | | | | 16.5 | | | | 28.0 |
| | 30.0 | 15.2 | 15.0 | | | 15.2 | 14.8/30.6m | | | 15.2 | 13.7/31.9m | | | 30.0 |
| | 32.0 | 14.0 | 13.8 | | | 14.0 | 13.7 | | | 14.0 | 13.6 | | | 32.0 |
| | 34.0 | 12.8 | 12.6 | | | 12.8 | 12.5 | | | 12.8 | 12.4 | | | 34.0 |
| | 36.0 | 11.6 | 11.6 | | | 11.8 | 11.5 | | | 11.8 | 11.4 | | | 36.0 |
| | 38.0 | 9.5 | 10.9 | | | 10.7 | 10.8 | | | 10.8 | 10.6 | | | 38.0 |
| | 40.0 | 8.9/38.7m | 10.1 | | | 9.5 | 10.0 | | | 9.8 | 9.8 | | | 40.0 |
| | 42.0 | | 9.5 | | | 7.9/41.7m | 9.4 | | | 8.8 | 9.2 | | | 42.0 |
| | 44.0 | | 8.9 | 8.7/44.5m | | | 8.8 | | | 7.4 | 8.6 | | | 44.0 |
| | 46.0 | | 8.4 | 8.3 | | | 8.2 | 8.1/46.2m | | 7.0/44.6m | 8.0 | | | 46.0 |
| | 48.0 | | 7.8 | 7.8 | | | 7.6 | 7.6 | | 7.4 | 7.4/48.0m | | | 48.0 |
| | 50.0 | | 7.7/48.7m | 7.4 | | | 7.2 | 7.2 | | 7.0 | 7.0 | | | 50.0 |
| | 52.0 | | | 7.0 | | | 6.8/51.7m | 6.8 | | 6.6 | 6.6 | | | 52.0 |
| | 54.0 | | | 6.6 | | | | 6.4 | | 6.2 | 6.2 | | | 54.0 |
| | 56.0 | | | 6.3 | | | | 6.1 | | 6.1/54.6m | 5.9 | | | 56.0 |
| | 58.0 | | | 6.0 | 5.8/58.3m | | | 5.8 | | | 5.6 | | | 58.0 |
| | 60.0 | | | 5.9/58.4m | 5.6 | | | 5.6 | 5.3/60.5m | | 5.4 | | | 60.0 |
| | 62.0 | | | | 5.3 | | | 5.4/61.3m | 5.1 | | 5.2 | 4.8/62.6m | | 62.0 |
| | 64.0 | | | | 5.0 | | | | 4.8 | | 4.9 | 4.6 | | 64.0 |
| | 66.0 | | | | 4.8 | | | | 4.6 | | 4.8/64.3m | 4.4 | | 66.0 |
| 68.0 | | | | 4.6/67.4m | | | | 4.4 | | | 4.2 | | 68.0 | |
| 70.0 | | | | | | | | 4.2 | | | 4.0 | | 70.0 | |
| 72.0 | | | | | | | | 4.2/70.3m | | | 3.8 | | 72.0 | |
| 74.0 | | | | | | | | | | | 3.6/73.3m | | 74.0 | |

※表中の太線で囲まれた部分は、ブーム等の強度によって定められた値です。

(単位:t)

| タワー長さm | | 58.0 | | | | | | | | | | タワー長さm | |
|---------|------|------------|------------|-----------|-----------|------------|------------|-----------|-----------|------------|------------|-----------|-------|
| ジブ長さm | | 45.7 | | | | 48.8 | | | | 51.8 | | ジブ長さm | |
| タワー角度 | | 90° | 80° | 70° | 60° | 90° | 80° | 70° | 60° | 90° | 80° | 70° | タワー角度 |
| 作業半径(m) | 14.0 | 17.4/15.7m | | | | | | | | | | | 14.0 |
| | 16.0 | 17.4 | | | | 15.4/16.5m | | | | 13.9/17.2m | | | 16.0 |
| | 18.0 | 16.9 | | | | 15.0 | | | | 13.7 | | | 18.0 |
| | 20.0 | 16.4 | | | | 14.6 | | | | 13.3 | | | 20.0 |
| | 22.0 | 16.0 | | | | 14.2 | | | | 12.8 | | | 22.0 |
| | 24.0 | 15.5 | | | | 13.7 | | | | 12.4 | | | 24.0 |
| | 26.0 | 15.0 | | | | 13.3 | | | | 12.0 | | | 26.0 |
| | 28.0 | 14.6 | | | | 12.9 | | | | 11.6 | | | 28.0 |
| | 30.0 | 14.1 | | | | 12.5 | | | | 11.2 | | | 30.0 |
| | 32.0 | 13.6 | 12.7/33.2m | | | 12.0 | | | | 10.8 | | | 32.0 |
| | 34.0 | 12.6 | 12.3 | | | 11.6 | 11.8/34.5m | | | 10.4 | 10.6/35.7m | | 34.0 |
| | 36.0 | 11.5 | 11.3 | | | 10.9 | 11.1 | | | 9.8 | 10.4 | | 36.0 |
| | 38.0 | 10.6 | 10.5 | | | 10.1 | 10.2 | | | 9.1 | 9.7 | | 38.0 |
| | 40.0 | 9.6 | 9.7 | | | 9.4 | 9.4 | | | 8.5 | 9.0 | | 40.0 |
| | 42.0 | 8.8 | 9.0 | | | 8.6 | 8.7 | | | 7.9 | 8.4 | | 42.0 |
| | 44.0 | 8.1 | 8.4 | | | 7.9 | 8.1 | | | 7.4 | 7.8 | | 44.0 |
| | 46.0 | 7.1 | 7.8 | | | 7.3 | 7.6 | | | 6.9 | 7.3 | | 46.0 |
| | 48.0 | 6.1/47.5m | 7.2 | 6.9/49.7m | | 6.6 | 7.0 | | | 6.3 | 6.8 | | 48.0 |
| | 50.0 | | 6.8 | 6.8 | | 5.6 | 6.6 | 6.3/51.5m | | 5.9 | 6.4 | | 50.0 |
| | 52.0 | | 6.4 | 6.4 | | 5.3/50.5m | 6.2 | 6.2 | | 5.4 | 6.0 | 5.7/53.2m | 52.0 |
| | 54.0 | | 6.0 | 6.0 | | | 5.8 | 5.8 | | 4.9/53.4m | 5.6 | 5.6 | 54.0 |
| | 56.0 | | 5.7 | 5.7 | | | 5.5 | 5.5 | | | 5.3 | 5.3 | 56.0 |
| | 58.0 | | 5.4/57.6m | 5.4 | | | 5.2 | 5.2 | | | 5.0 | 5.0 | 58.0 |
| | 60.0 | | | 5.2 | | | 5.0 | 5.0 | | | 4.8 | 4.8 | 60.0 |
| | 62.0 | | | 5.0 | | | 4.9/60.5m | 4.8 | | | 4.6 | 4.6 | 62.0 |
| | 64.0 | | | 4.8 | 4.3/64.8m | | | 4.6 | | | 4.3/63.5m | 4.4 | 64.0 |
| | 66.0 | | | 4.6 | 4.2 | | | 4.4 | 3.9/66.9m | | | 4.2 | 66.0 |
| | 68.0 | | | 4.4/67.2m | 4.0 | | | 4.2 | 3.8 | | | 4.0 | 68.0 |
| 70.0 | | | | 3.8 | | | 4.0 | 3.6 | | | 3.8 | 70.0 | |
| 72.0 | | | | 3.6 | | | 4.0/70.2m | 3.4 | | | 3.6 | 72.0 | |
| 74.0 | | | | 3.4 | | | | 3.2 | | | 3.5/73.1m | 74.0 | |
| 76.0 | | | | 3.2 | | | | 3.0 | | | | 76.0 | |
| 78.0 | | | | 3.2/76.2m | | | | 2.8 | | | | 78.0 | |
| 80.0 | | | | | | | | 2.7/79.2m | | | | 80.0 | |

※表中の太線で囲まれた部分は、ブーム等の強度によって定められた値です。

▶タワー長さ 61.0m

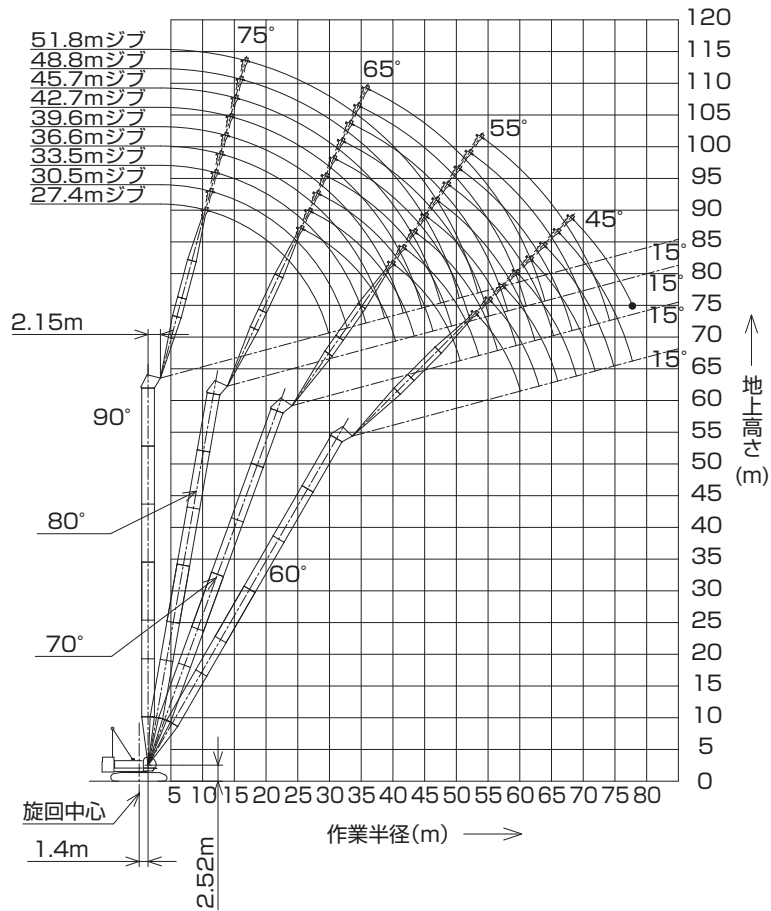

(単位:t)

| タワー長さm | 61.0 | | | | | | | | | | | | タワー長さm |
|----------|------|------------|------------|------------|------------|------------|-----------|-----|------------|------------|-----------|------|--------|
| ジブ長さm | 27.4 | | | | 30.5 | | | | 33.5 | | | | ジブ長さm |
| タワー角度 | 90° | 80° | 70° | 60° | 90° | 80° | 70° | 60° | 90° | 80° | 70° | 60° | タワー角度 |
| 作業半径 (m) | 10.0 | 25.0/10.9m | | | 25.0/11.7m | | | | 25.0/12.5m | | | | 10.0 |
| | 12.0 | 25.0 | | | 25.0 | | | | 25.0 | | | | 12.0 |
| | 14.0 | 25.0 | | | 25.0 | | | | 25.0 | | | | 14.0 |
| | 16.0 | 24.6 | | | 24.6 | | | | 24.0 | | | | 16.0 |
| | 18.0 | 23.7 | | | 23.7 | | | | 23.0 | | | | 18.0 |
| | 20.0 | 22.9 | | | 22.7 | | | | 22.0 | | | | 20.0 |
| | 22.0 | 21.5 | | | 21.5 | | | | 21.0 | | | | 22.0 |
| | 24.0 | 20.0 | | | 20.0 | | | | 20.0 | | | | 24.0 |
| | 26.0 | 18.3 | 18.6/26.0m | | 18.6 | 17.4/27.3m | | | 18.8 | | | | 26.0 |
| | 28.0 | 16.3 | 16.8 | | 16.7 | 16.7 | | | 16.7 | 16.4/28.5m | | | 28.0 |
| | 30.0 | 11.3/29.9m | 15.2 | | 15.1 | 15.1 | | | 15.3 | 15.1 | | | 30.0 |
| | 32.0 | | 14.0 | | 12.0 | 13.9 | | | 14.0 | 13.9 | | | 32.0 |
| | 34.0 | | 12.8 | | 10.6/32.8m | 12.7 | | | 12.3 | 12.7 | | | 34.0 |
| | 36.0 | | 11.8 | | | 11.7 | | | 9.4/35.8m | 11.7 | | | 36.0 |
| | 38.0 | | 11.1 | | | 11.0 | | | | 11.0 | | | 38.0 |
| | 40.0 | | 10.4 | 10.3/40.3m | | 10.3 | | | | 10.2 | | | 40.0 |
| | 42.0 | | 10.2/40.4m | 9.7 | | 9.5 | 9.6/42.0m | | | 9.6 | 8.8/43.8m | | 42.0 |
| | 44.0 | | | 9.1 | | 9.2/43.4m | 9.0 | | | 8.9 | 8.8 | | 44.0 |
| | 46.0 | | | 8.6 | | | 8.5 | | | 8.4 | 8.4 | | 46.0 |
| | 48.0 | | | 8.2 | | | 8.0 | | | 8.4/46.3m | 7.9 | | 48.0 |
| 50.0 | | | 7.8 | | | 7.6 | | | | 7.5 | | 50.0 | |
| 52.0 | | | 7.7/50.6m | 6.8/53.4m | | 7.3 | | | | 7.1 | | 52.0 | |
| 54.0 | | | | 6.7 | | 6.9/53.6m | 6.4/55.5m | | | 6.7 | | 54.0 | |
| 56.0 | | | | 6.4 | | | 6.3 | | | 6.4 | 5.7/57.7m | 56.0 | |
| 58.0 | | | | 6.1 | | | 6.0 | | | 6.3/56.5m | 5.7 | 58.0 | |
| 60.0 | | | | 5.8 | | | 5.7 | | | | 5.5 | 60.0 | |
| 62.0 | | | | 5.8/60.1m | | | 5.4 | | | | 5.2 | 62.0 | |
| 64.0 | | | | | | | 5.2/63.0m | | | | 5.0 | 64.0 | |
| 66.0 | | | | | | | | | | | 4.8 | 66.0 | |
| 68.0 | | | | | | | | | | | 4.8/66.0m | 68.0 | |

※表中の太線で囲まれた部分は、ブーム等の強度によって定められた値です。

(単位:t)

| タワー長さm | | 61.0 | | | | | | | | | | | | タワー長さm |
|---------|------|------------|------------|-----------|-----------|------------|------------|-----------|-----------|------------|------------|-----------|-----------|--------|
| ジブ長さm | | 36.6 | | | | 39.6 | | | | 42.7 | | | | ジブ長さm |
| タワー角度 | | 90° | 80° | 70° | 60° | 90° | 80° | 70° | 60° | 90° | 80° | 70° | 60° | タワー角度 |
| 作業半径(m) | 12.0 | 23.9/13.3m | | | | | | | | | | | | 12.0 |
| | 14.0 | 23.6 | | | | 22.0/14.1m | | | | 20.0/14.9m | | | | 14.0 |
| | 16.0 | 22.9 | | | | 21.4 | | | | 19.7 | | | | 16.0 |
| | 18.0 | 22.2 | | | | 20.8 | | | | 19.2 | | | | 18.0 |
| | 20.0 | 21.4 | | | | 20.2 | | | | 18.6 | | | | 20.0 |
| | 22.0 | 20.7 | | | | 19.6 | | | | 18.1 | | | | 22.0 |
| | 24.0 | 19.9 | | | | 19.0 | | | | 17.5 | | | | 24.0 |
| | 26.0 | 18.8 | | | | 18.3 | | | | 17.0 | | | | 26.0 |
| | 28.0 | 16.8 | 15.2/29.8m | | | 16.8 | | | | 16.5 | | | | 28.0 |
| | 30.0 | 15.2 | 15.0 | | | 15.2 | 14.3/31.1m | | | 15.2 | | | | 30.0 |
| | 32.0 | 14.0 | 13.8 | | | 14.0 | 13.7 | | | 14.0 | 13.5/32.4m | | | 32.0 |
| | 34.0 | 12.8 | 12.6 | | | 12.8 | 12.5 | | | 12.8 | 12.4 | | | 34.0 |
| | 36.0 | 11.5 | 11.6 | | | 11.8 | 11.5 | | | 11.8 | 11.4 | | | 36.0 |
| | 38.0 | 9.5 | 10.9 | | | 10.7 | 10.8 | | | 10.8 | 10.6 | | | 38.0 |
| | 40.0 | 8.9/38.7m | 10.1 | | | 9.5 | 10.0 | | | 9.8 | 9.8 | | | 40.0 |
| | 42.0 | | 9.5 | | | 7.9/41.7m | 9.4 | | | 8.9 | 9.2 | | | 42.0 |
| | 44.0 | | 8.9 | 8.4/45.5m | | | 8.8 | | | 7.4 | 8.6 | | | 44.0 |
| | 46.0 | | 8.4 | 8.3 | | | 8.2 | 7.8/47.3m | | 6.9/44.6m | 8.0 | | | 46.0 |
| | 48.0 | | 7.8 | 7.8 | | | 7.6 | 7.6 | | | 7.4 | 7.2/49.0m | | 48.0 |
| | 50.0 | | 7.5/49.3m | 7.4 | | | 7.2 | 7.2 | | | 7.0 | 7.0 | | 50.0 |
| | 52.0 | | | 7.0 | | | 6.8 | 6.8 | | | 6.6 | 6.6 | | 52.0 |
| | 54.0 | | | 6.6 | | | 6.8/52.2m | 6.4 | | | 6.2 | 6.2 | | 54.0 |
| | 56.0 | | | 6.3 | | | | 6.1 | | | 5.9/55.2m | 5.9 | | 56.0 |
| | 58.0 | | | 6.0 | 5.3/59.8m | | | 5.8 | | | | 5.6 | | 58.0 |
| | 60.0 | | | 5.8/59.4m | 5.3 | | | 5.6 | | | | 5.4 | | 60.0 |
| | 62.0 | | | | 5.1 | | | 5.4 | 4.9/62.0m | | | 5.2 | | 62.0 |
| | 64.0 | | | | 4.9 | | | 5.3/62.4m | 4.7 | | | 5.0 | 4.0/64.1m | 64.0 |
| | 66.0 | | | | 4.7 | | | | 4.5 | | | 4.9/65.3m | 4.0 | 66.0 |
| 68.0 | | | | 4.4 | | | | 4.2 | | | | 3.8 | 68.0 | |
| 70.0 | | | | 4.3/68.9m | | | | 3.9 | | | | 3.6 | 70.0 | |
| 72.0 | | | | | | | | 3.6 | | | | 3.4 | 72.0 | |
| 74.0 | | | | | | | | 3.6/71.9m | | | | 3.2 | 74.0 | |
| 76.0 | | | | | | | | | | | | 3.1/74.8m | 76.0 | |

※表中の太線で囲まれた部分は、ブーム等の強度によって定められた値です。

(単位:t)

| タワー長さm | | 61.0 | | | | | | | | | | | | タワー長さm |
|---------|------|------------|------------|-----------|-----------|------------|------------|-----------|-----|------------|-----------|-----------|-------|--------|
| ジブ長さm | | 45.7 | | | | 48.8 | | | | 51.8 | | | | ジブ長さm |
| タワー角度 | | 90° | 80° | 70° | 60° | 90° | 80° | 70° | 60° | 90° | 80° | 70° | タワー角度 | |
| 作業半径(m) | 14.0 | 17.4/15.7m | | | | | | | | | | | 14.0 | |
| | 16.0 | 17.4 | | | | 15.4/16.5m | | | | 13.9/17.2m | | | 16.0 | |
| | 18.0 | 16.9 | | | | 15.0 | | | | 13.7 | | | 18.0 | |
| | 20.0 | 16.4 | | | | 14.6 | | | | 13.3 | | | 20.0 | |
| | 22.0 | 16.0 | | | | 14.2 | | | | 12.8 | | | 22.0 | |
| | 24.0 | 15.5 | | | | 13.7 | | | | 12.4 | | | 24.0 | |
| | 26.0 | 15.0 | | | | 13.3 | | | | 12.0 | | | 26.0 | |
| | 28.0 | 14.6 | | | | 12.9 | | | | 11.6 | | | 28.0 | |
| | 30.0 | 14.1 | | | | 12.5 | | | | 11.2 | | | 30.0 | |
| | 32.0 | 13.6 | 12.6/33.7m | | | 12.0 | | | | 10.8 | | | 32.0 | |
| | 34.0 | 12.6 | 12.3 | | | 11.6 | 11.4/35.0m | | | 10.4 | | | 34.0 | |
| | 36.0 | 11.5 | 11.3 | | | 10.8 | 11.0 | | | 9.8 | 9.7/36.3m | | 36.0 | |
| | 38.0 | 10.4 | 10.5 | | | 9.9 | 10.1 | | | 9.1 | 9.3 | | 38.0 | |
| | 40.0 | 9.5 | 9.7 | | | 9.3 | 9.3 | | | 8.5 | 8.7 | | 40.0 | |
| | 42.0 | 8.7 | 9.0 | | | 8.5 | 8.6 | | | 7.9 | 8.2 | | 42.0 | |
| | 44.0 | 8.1 | 8.4 | | | 7.8 | 8.0 | | | 7.4 | 7.6 | | 44.0 | |
| | 46.0 | 7.2 | 7.8 | | | 7.3 | 7.5 | | | 6.9 | 7.1 | | 46.0 | |
| | 48.0 | 6.2/47.5m | 7.2 | | | 6.6 | 6.9 | | | 6.3 | 6.6 | | 48.0 | |
| | 50.0 | | 6.8 | 6.7/50.8m | | 5.6 | 6.5 | | | 5.8 | 6.2 | | 50.0 | |
| | 52.0 | | 6.4 | 6.4 | | 5.3/50.5m | 6.1 | 6.0/52.5m | | 5.3 | 5.8 | | 52.0 | |
| | 54.0 | | 6.0 | 6.0 | | | 5.7 | 5.7 | | 4.9/53.4m | 5.4 | 5.3/54.2m | 54.0 | |
| | 56.0 | | 5.7 | 5.7 | | | 5.4 | 5.4 | | | 5.1 | 5.1 | 56.0 | |
| | 58.0 | | 5.4 | 5.4 | | | 5.1 | 5.1 | | | 4.8 | 4.8 | 58.0 | |
| | 60.0 | | 5.4/58.1m | 5.2 | | | 4.9 | 4.9 | | | 4.6 | 4.6 | 60.0 | |
| | 62.0 | | | 5.0 | | | 4.7/61.0m | 4.7 | | | 4.4 | 4.4 | 62.0 | |
| | 64.0 | | | 4.8 | | | | 4.5 | | | 4.1/64.0m | 4.2 | 64.0 | |
| | 66.0 | | | 4.6 | 3.7/66.3m | | | 4.3 | | | | 4.0 | 66.0 | |
| | 68.0 | | | 4.3 | 3.5 | | | 4.1 | | | | 3.8 | 68.0 | |
| 70.0 | | | 4.3/68.3m | 3.3 | | | 3.9 | 3.1/70.0m | | | 3.6 | 70.0 | | |
| 72.0 | | | | 3.1 | | | 3.8/71.2m | 2.9 | | | 3.4 | 72.0 | | |
| 74.0 | | | | 2.9 | | | | 2.7 | | | 3.2 | 74.0 | | |
| 76.0 | | | | 2.7 | | | | 2.5 | | | 3.2/74.2m | 76.0 | | |
| 78.0 | | | | 2.5/77.8m | | | | 2.3/78.0m | | | | 78.0 | | |

※表中の太線で囲まれた部分は、ブーム等の強度によって定められた値です。

▶タワー長さ 64.1m

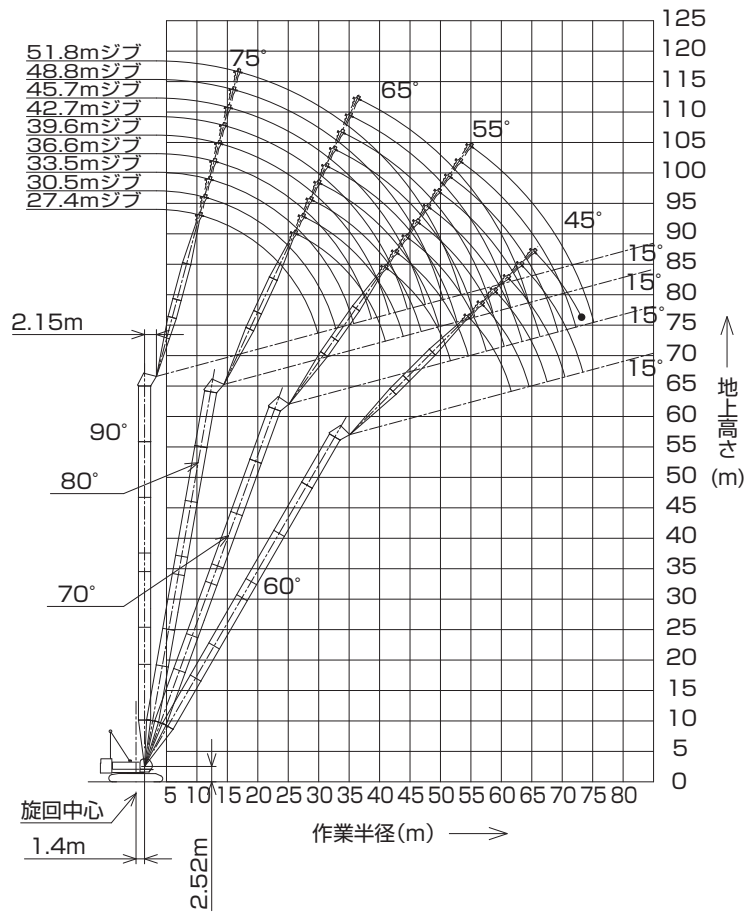

(単位:t)

| タワー長さm | 64.1 | | | | | | | | | | | | タワー長さm |
|----------|------|------------|------------|-----------|------------|------------|-----------|-----|------------|------------|-----------|------|--------|
| ジブ長さm | 27.4 | | | | 30.5 | | | | 33.5 | | | | ジブ長さm |
| タワー角度 | 90° | 80° | 70° | 60° | 90° | 80° | 70° | 60° | 90° | 80° | 70° | 60° | タワー角度 |
| 作業半径 (m) | 10.0 | 25.0/10.9m | | | 25.0/11.7m | | | | | | | | 10.0 |
| | 12.0 | 25.0 | | | 25.0 | | | | 24.8/12.5m | | | | 12.0 |
| | 14.0 | 24.3 | | | 24.3 | | | | 24.3 | | | | 14.0 |
| | 16.0 | 23.6 | | | 23.6 | | | | 23.6 | | | | 16.0 |
| | 18.0 | 22.9 | | | 22.9 | | | | 22.9 | | | | 18.0 |
| | 20.0 | 22.2 | | | 22.2 | | | | 22.0 | | | | 20.0 |
| | 22.0 | 21.5 | | | 21.5 | | | | 21.0 | | | | 22.0 |
| | 24.0 | 20.0 | | | 20.0 | | | | 20.0 | | | | 24.0 |
| | 26.0 | 18.3 | 18.3/26.5m | | 18.6 | 15.9/27.8m | | | 18.8 | | | | 26.0 |
| | 28.0 | 16.3 | 16.8 | | 16.7 | 16.7 | | | 16.7 | 15.9/29.1m | | | 28.0 |
| | 30.0 | 11.3/29.9m | 15.2 | | 15.1 | 15.1 | | | 15.3 | 15.1 | | | 30.0 |
| | 32.0 | | 14.0 | | 12.0 | 13.9 | | | 14.0 | 13.9 | | | 32.0 |
| | 34.0 | | 12.8 | | 10.6/32.8m | 12.7 | | | 12.3 | 12.7 | | | 34.0 |
| | 36.0 | | 11.8 | | | 11.7 | | | 9.4/35.8m | 11.7 | | | 36.0 |
| | 38.0 | | 11.1 | | | 11.0 | | | | 11.0 | | | 38.0 |
| | 40.0 | | 10.4 | 9.9/41.3m | | 10.3 | | | | 10.2 | | | 40.0 |
| | 42.0 | | 10.0/41.0m | 9.7 | | 9.5 | 9.3/43.1m | | | 9.6 | | | 42.0 |
| | 44.0 | | | 9.1 | | | 9.0/43.9m | 9.0 | | 8.9 | 8.7/44.8m | | 44.0 |
| | 46.0 | | | 8.6 | | | 8.5 | | | 8.4 | 8.4 | | 46.0 |
| | 48.0 | | | 8.2 | | | 8.0 | | | 8.2/46.9m | 7.9 | | 48.0 |
| 50.0 | | | 7.8 | | | 7.6 | | | | 7.5 | | 50.0 | |
| 52.0 | | | 7.4/51.7m | | | 7.3 | | | | 7.1 | | 52.0 | |
| 54.0 | | | | 6.0/54.9m | | 6.9 | | | | 6.7 | | 54.0 | |
| 56.0 | | | | 5.9 | | 6.7/54.6m | 5.4/57.1m | | | 6.4 | | 56.0 | |
| 58.0 | | | | 5.7 | | | 5.3 | | | 6.2/57.5m | 4.9/59.2m | 58.0 | |
| 60.0 | | | | 5.5 | | | 5.1 | | | | 4.8 | 60.0 | |
| 62.0 | | | | 5.3/61.6m | | | 4.9 | | | | 4.6 | 62.0 | |
| 64.0 | | | | | | | 4.7 | | | | 4.4 | 64.0 | |
| 66.0 | | | | | | | 4.6/64.6m | | | | 4.2 | 66.0 | |
| 68.0 | | | | | | | | | | | 4.0/67.5m | 68.0 | |

※表中の太線で囲まれた部分は、ブーム等の強度によって定められた値です。

(単位:t)

| タワー長さm | | 64.1 | | | | | | | | | | | | タワー長さm |
|---------|------|------------|------------|-----------|-----------|------------|------------|-----------|-----------|------------|------------|-----------|-----------|--------|
| ジブ長さm | | 36.6 | | | | 39.6 | | | | 42.7 | | | | ジブ長さm |
| タワー角度 | | 90° | 80° | 70° | 60° | 90° | 80° | 70° | 60° | 90° | 80° | 70° | 60° | タワー角度 |
| 作業半径(m) | 12.0 | 23.9/13.3m | | | | | | | | | | | | 12.0 |
| | 14.0 | 23.6 | | | | 22.0/14.1m | | | | 20.0/14.9m | | | | 14.0 |
| | 16.0 | 22.9 | | | | 21.4 | | | | 19.7 | | | | 16.0 |
| | 18.0 | 22.2 | | | | 20.8 | | | | 19.2 | | | | 18.0 |
| | 20.0 | 21.4 | | | | 20.2 | | | | 18.6 | | | | 20.0 |
| | 22.0 | 20.7 | | | | 19.6 | | | | 18.1 | | | | 22.0 |
| | 24.0 | 19.9 | | | | 19.0 | | | | 17.5 | | | | 24.0 |
| | 26.0 | 18.8 | | | | 18.3 | | | | 17.0 | | | | 26.0 |
| | 28.0 | 16.8 | | | | 16.8 | | | | 16.5 | | | | 28.0 |
| | 30.0 | 15.2 | 14.9/30.4m | | | 15.2 | 13.9/31.7m | | | 15.2 | | | | 30.0 |
| | 32.0 | 14.0 | 13.8 | | | 14.0 | 13.7 | | | 14.0 | 13.3/32.9m | | | 32.0 |
| | 34.0 | 12.8 | 12.6 | | | 12.8 | 12.5 | | | 12.8 | 12.4 | | | 34.0 |
| | 36.0 | 11.5 | 11.6 | | | 11.8 | 11.5 | | | 11.8 | 11.4 | | | 36.0 |
| | 38.0 | 9.5 | 10.9 | | | 10.7 | 10.8 | | | 10.8 | 10.6 | | | 38.0 |
| | 40.0 | 8.9/38.7m | 10.1 | | | 9.5 | 10.0 | | | 9.7 | 9.8 | | | 40.0 |
| | 42.0 | | 9.5 | | | 7.9/41.7m | 9.4 | | | 8.8 | 9.2 | | | 42.0 |
| | 44.0 | | 8.9 | | | | 8.8 | | | 8.8 | 8.6 | | | 44.0 |
| | 46.0 | | 8.4 | 8.1/46.5m | | | 8.2 | | | 6.9/44.6m | 8.0 | | | 46.0 |
| | 48.0 | | 7.8 | 7.8 | | | 7.6 | 7.6/48.3m | | | 7.4 | | | 48.0 |
| | 50.0 | | 7.4/49.8m | 7.4 | | | 7.2 | 7.2 | | | 7.0 | 7.0/50.0m | | 50.0 |
| | 52.0 | | | 7.0 | | | 6.7 | 6.8 | | | 6.6 | 6.6 | | 52.0 |
| | 54.0 | | | 6.6 | | | 6.6/52.7m | 6.4 | | | 6.1 | 6.2 | | 54.0 |
| | 56.0 | | | 6.3 | | | | 6.1 | | | 5.8/55.7m | 5.9 | | 56.0 |
| | 58.0 | | | 6.0 | | | | 5.8 | | | | 5.6 | | 58.0 |
| | 60.0 | | | 5.7 | 4.5/61.4m | | | 5.6 | | | | 5.4 | | 60.0 |
| | 62.0 | | | 5.6/60.5m | 4.4 | | | 5.4 | 4.0/63.5m | | | 5.2 | | 62.0 |
| | 64.0 | | | | 4.2 | | | 5.3/63.4m | 4.0 | | | 5.0 | | 64.0 |
| | 66.0 | | | | 4.0 | | | | 3.8 | | | 4.8 | 3.4/66.0m | 66.0 |
| 68.0 | | | | 3.8 | | | | 3.6 | | | 4.7/66.4m | 3.4 | 68.0 | |
| 70.0 | | | | 3.6 | | | | 3.4 | | | | 3.2 | 70.0 | |
| 72.0 | | | | 3.5/70.5m | | | | 3.2 | | | | 3.0 | 72.0 | |
| 74.0 | | | | | | | | 3.0/73.4m | | | | 2.8/74.0m | 74.0 | |

※表中の太線で囲まれた部分は、ブーム等の強度によって定められた値です。

(単位:t)

| タワー長さm | | 64.1 | | | | | | | | | タワー長さm |
|---------|------|------------|------------|-----------|------------|------------|-----------|------------|-----------|-----------|--------|
| ジブ長さm | | 45.7 | | | 48.8 | | | 51.8 | | | ジブ長さm |
| タワー角度 | | 90° | 80° | 70° | 90° | 80° | 70° | 90° | 80° | 70° | タワー角度 |
| 作業半径(m) | 14.0 | 17.4/15.7m | | | | | | | | | 14.0 |
| | 16.0 | 17.4 | | | 15.4/16.5m | | | 13.9/17.2m | | | 16.0 |
| | 18.0 | 16.9 | | | 15.0 | | | 13.7 | | | 18.0 |
| | 20.0 | 16.4 | | | 14.6 | | | 13.3 | | | 20.0 |
| | 22.0 | 16.0 | | | 14.2 | | | 12.8 | | | 22.0 |
| | 24.0 | 15.5 | | | 13.7 | | | 12.4 | | | 24.0 |
| | 26.0 | 15.0 | | | 13.3 | | | 11.9 | | | 26.0 |
| | 28.0 | 14.6 | | | 12.9 | | | 11.5 | | | 28.0 |
| | 30.0 | 14.1 | | | 12.5 | | | 11.1 | | | 30.0 |
| | 32.0 | 13.6 | | | 12.0 | | | 10.8 | | | 32.0 |
| | 34.0 | 12.6 | 12.3/34.2m | | 11.6 | 11.4/35.5m | | 10.4 | | | 34.0 |
| | 36.0 | 11.5 | 11.3 | | 10.8 | 11.0 | | 9.8 | 9.2/36.8m | | 36.0 |
| | 38.0 | 10.4 | 10.5 | | 9.9 | 10.1 | | 9.1 | 9.0 | | 38.0 |
| | 40.0 | 9.5 | 9.7 | | 9.3 | 9.3 | | 8.5 | 8.4 | | 40.0 |
| | 42.0 | 8.7 | 9.0 | | 8.5 | 8.6 | | 7.9 | 7.9 | | 42.0 |
| | 44.0 | 7.9 | 8.4 | | 7.8 | 8.0 | | 7.4 | 7.3 | | 44.0 |
| | 46.0 | 7.1 | 7.8 | | 7.1 | 7.5 | | 6.8 | 6.8 | | 46.0 |
| | 48.0 | 6.2/47.5m | 7.2 | | 6.4 | 6.9 | | 6.2 | 6.3 | | 48.0 |
| | 50.0 | | 6.8 | 6.4/51.8m | 5.6 | 6.5 | | 5.6 | 5.9 | | 50.0 |
| | 52.0 | | 6.4 | 6.4 | 5.3/50.5m | 6.1 | 5.8/53.5m | 5.0 | 5.5 | | 52.0 |
| | 54.0 | | 6.0 | 6.0 | | 5.7 | 5.7 | 4.5/53.4m | 5.1 | 4.9/55.3m | 54.0 |
| | 56.0 | | 5.7 | 5.7 | | 5.4 | 5.4 | | 4.8 | 4.8 | 56.0 |
| | 58.0 | | 5.4 | 5.4 | | 5.1 | 5.1 | | 4.5 | 4.5 | 58.0 |
| | 60.0 | | 5.3/58.6m | 5.2 | | 4.9 | 4.9 | | 4.3 | 4.3 | 60.0 |
| | 62.0 | | | 5.0 | | 4.7/61.6m | 4.7 | | 4.1 | 4.1 | 62.0 |
| | 64.0 | | | 4.8 | | | 4.5 | | 3.8 | 3.9 | 64.0 |
| | 66.0 | | | 4.6 | | | 4.3 | | 3.7/64.5m | 3.7 | 66.0 |
| | 68.0 | | | 4.4 | | | 4.1 | | | 3.5 | 68.0 |
| 70.0 | | | 4.3/69.3m | | | 3.9 | | | 3.3 | 70.0 | |
| 72.0 | | | | | | 3.8 | | | 3.1 | 72.0 | |
| 74.0 | | | | | | 3.7/72.3m | | | 3.0 | 74.0 | |
| 76.0 | | | | | | | | | 2.9/75.2m | 76.0 | |

※表中の太線で囲まれた部分は、ブーム等の強度によって定められた値です。

▶ タワー長さ36.6m (75.1tカウンタウエイト／カーボディウエイトなし)(オプション)

(単位:t)

| タワー長さm | 36.6 | | | | | | | | タワー長さm |
|--------|------------|------------|------------|-----------|------------|------------|------------|-----------|--------|
| ジブ長さm | 27.4 | | | | 30.5 | | | | ジブ長さm |
| タワー角度 | 90° | 80° | 70° | 60° | 90° | 80° | 70° | 60° | タワー角度 |
| 10.0 | 25.0/10.9m | | | | 24.4/11.7m | | | | 10.0 |
| 12.0 | 25.0 | | | | 24.2 | | | | 12.0 |
| 14.0 | 25.0 | | | | 23.8 | | | | 14.0 |
| 16.0 | 24.6 | | | | 23.4 | | | | 16.0 |
| 18.0 | 24.2 | | | | 23.0 | | | | 18.0 |
| 20.0 | 23.8 | 19.0/21.7m | | | 22.6 | | | | 20.0 |
| 22.0 | 23.1 | 18.3 | | | 22.2 | 18.2/23.0m | | | 22.0 |
| 24.0 | 19.9 | 16.3 | | | 20.3 | 16.2 | | | 24.0 |
| 26.0 | 17.1 | 14.8 | | | 17.7 | 14.7 | | | 26.0 |
| 28.0 | 14.1 | 13.4 | | | 15.5 | 13.3 | | | 28.0 |
| 30.0 | 10.2/29.9m | 12.3 | 11.6/31.9m | | 13.4 | 12.2 | | | 30.0 |
| 32.0 | | 11.4 | 11.4 | | 10.5 | 11.3 | 10.5/33.7m | | 32.0 |
| 34.0 | | 10.6 | 10.6 | | 8.9/32.8m | 10.5 | 10.4 | | 34.0 |
| 36.0 | | 9.9 | 9.9 | | | 9.8 | 9.7 | | 36.0 |
| 38.0 | | 8.2/36.2m | 9.3 | | | 9.2 | 9.1 | | 38.0 |
| 40.0 | | | 8.8 | 8.5/41.2m | | 8.9/39.2m | 8.6 | | 40.0 |
| 42.0 | | | 8.3 | 8.2 | | | 8.1 | 7.6/43.3m | 42.0 |
| 44.0 | | | 8.2/42.3m | 7.7 | | | 7.6 | 7.4 | 44.0 |
| 46.0 | | | | 7.2 | | | 7.5/45.2m | 7.0 | 46.0 |
| 48.0 | | | | 6.7/47.9m | | | | 6.6 | 48.0 |
| 50.0 | | | | | | | | 6.2 | 50.0 |
| 52.0 | | | | | | | | 6.0/50.8m | 52.0 |

※表中の太線で囲まれた部分は、ブーム等の強度によって定められた値です。
ジブ長さ27.4mでの、ボールフックの使用はできません。

▶ タワー長さ39.7m (75.1tカウンタウエイト／カーボディウエイトなし)(オプション)

(単位:t)

| タワー長さm | 39.7 | | | | | | | | タワー長さm | | | | |
|--------|------------|------------|------------|-----------|------------|------------|------------|-----------|------------|------------|-----------|-----------|-------|
| ジブ長さm | 27.4 | | | | 30.5 | | | | 33.5 | | | | ジブ長さm |
| タワー角度 | 90° | 80° | 70° | 60° | 90° | 80° | 70° | 60° | 90° | 80° | 70° | 60° | タワー角度 |
| 10.0 | 25.0/10.9m | | | | 24.4/11.7m | | | | | | | | 10.0 |
| 12.0 | 25.0 | | | | 24.2 | | | | 22.7/12.5m | | | | 12.0 |
| 14.0 | 25.0 | | | | 23.8 | | | | 22.3 | | | | 14.0 |
| 16.0 | 24.6 | | | | 23.4 | | | | 21.9 | | | | 16.0 |
| 18.0 | 24.2 | | | | 23.0 | | | | 21.5 | | | | 18.0 |
| 20.0 | 23.8 | | | | 22.6 | | | | 21.1 | | | | 20.0 |
| 22.0 | 23.1 | 18.3/22.3m | | | 22.2 | 16.8/23.6m | | | 20.7 | | | | 22.0 |
| 24.0 | 19.9 | 16.3 | | | 20.3 | 16.2 | | | 20.3 | 15.7/24.8m | | | 24.0 |
| 26.0 | 17.1 | 14.8 | | | 17.7 | 14.7 | | | 18.0 | 14.6 | | | 26.0 |
| 28.0 | 14.1 | 13.4 | | | 15.5 | 13.3 | | | 15.9 | 13.2 | | | 28.0 |
| 30.0 | 10.2/29.9m | 12.3 | | | 13.4 | 12.2 | | | 14.0 | 12.1 | | | 30.0 |
| 32.0 | | 11.4 | 11.0/33.0m | | 10.5 | 11.3 | | | 12.3 | 11.2 | | | 32.0 |
| 34.0 | | 10.6 | 10.6 | | 8.9/32.8m | 10.5 | 10.4/34.7m | | 10.3 | 10.4 | | | 34.0 |
| 36.0 | | 9.9 | 9.9 | | | 9.8 | 9.7 | | 7.8/35.8m | 9.7 | 9.6/36.5m | | 36.0 |
| 38.0 | | 9.6/36.7m | 9.3 | | | 9.2 | 9.1 | | | 9.1 | 8.9 | | 38.0 |
| 40.0 | | | 8.8 | | | 8.8/39.7m | 8.6 | | | 8.6 | 8.4 | | 40.0 |
| 42.0 | | | 8.3 | 7.7/42.7m | | | 8.1 | | | 8.1 | 7.9 | | 42.0 |
| 44.0 | | | 7.9/43.3m | 7.4 | | | 7.6 | 7.1/44.9m | | 7.9/42.6m | 7.4 | | 44.0 |
| 46.0 | | | | 7.0 | | | 7.2 | 6.9 | | | 7.0 | 6.6/47.0m | 46.0 |
| 48.0 | | | | 6.6 | | | 7.1/46.3m | 6.5 | | | 6.6 | 6.4 | 48.0 |
| 50.0 | | | | 6.3/49.4m | | | | 6.1 | | | 6.3/49.2m | 6.0 | 50.0 |
| 52.0 | | | | | | | | 5.7 | | | | 5.6 | 52.0 |
| 54.0 | | | | | | | | 5.6/52.4m | | | | 5.2 | 54.0 |
| 56.0 | | | | | | | | | | | | 4.9/55.3m | 56.0 |

※表中の太線で囲まれた部分は、ブーム等の強度によって定められた値です。
ジブ長さ27.4mでの、ボールフックの使用はできません。

▶ タワー長さ42.7m (75.1tカウンタウエイト/カーボディウエイトなし)(オプション)

(単位:t)

| タワー長さm | 42.7 | | | | | | | | | | | | | | | | タワー長さm |
|--------|------------|------------|-----------|-----------|------------|------------|-----------|-----------|------------|------------|-----------|-----------|------------|------------|-----------|-----------|--------|
| ジブ長さm | 27.4 | | | | 30.5 | | | | 33.5 | | | | 36.6 | | | | ジブ長さm |
| タワー角度 | 90° | 80° | 70° | 60° | 90° | 80° | 70° | 60° | 90° | 80° | 70° | 60° | 90° | 80° | 70° | 60° | タワー角度 |
| 10.0 | 25.0/10.9m | | | | 24.4/11.7m | | | | | | | | | | | | 10.0 |
| 12.0 | 25.0 | | | | 24.2 | | | | 22.7/12.5m | | | | 21.0/13.3m | | | | 12.0 |
| 14.0 | 25.0 | | | | 23.8 | | | | 22.3 | | | | 20.8 | | | | 14.0 |
| 16.0 | 24.6 | | | | 23.4 | | | | 21.9 | | | | 20.4 | | | | 16.0 |
| 18.0 | 24.2 | | | | 23.0 | | | | 21.5 | | | | 20.0 | | | | 18.0 |
| 20.0 | 23.8 | | | | 22.6 | | | | 21.1 | | | | 19.6 | | | | 20.0 |
| 22.0 | 23.1 | 17.8/22.8m | | | 22.2 | | | | 20.7 | | | | 19.2 | | | | 22.0 |
| 24.0 | 19.9 | 16.3 | | | 20.3 | 16.2/24.1m | | | 20.3 | 15.2/25.4m | | | 18.8 | | | | 24.0 |
| 26.0 | 17.1 | 14.8 | | | 17.7 | 14.7 | | | 18.0 | 14.6 | | | 18.3 | 14.1/26.7m | | | 26.0 |
| 28.0 | 14.1 | 13.4 | | | 15.5 | 13.3 | | | 15.9 | 13.2 | | | 16.2 | 13.1 | | | 28.0 |
| 30.0 | 10.2/29.9m | 12.3 | | | 13.4 | 12.2 | | | 14.0 | 12.1 | | | 14.4 | 12.0 | | | 30.0 |
| 32.0 | | 11.4 | | | 10.5 | 11.3 | | | 12.3 | 11.2 | | | 12.8 | 11.1 | | | 32.0 |
| 34.0 | | 10.6 | 10.6 | | 8.9/32.8m | 10.5 | 9.8/35.8m | | 10.3 | 10.4 | | | 11.4 | 10.3 | | | 34.0 |
| 36.0 | | 9.9 | 9.9 | | | 9.8 | 9.7 | | 7.8/35.8m | 9.7 | | | 10.0 | 9.6 | | | 36.0 |
| 38.0 | | 9.5/37.3m | 9.3 | | | 9.2 | 9.1 | | | 9.1 | 8.9 | | 8.0 | 9.0 | 8.5/39.3m | | 38.0 |
| 40.0 | | | 8.8 | | | 8.7 | 8.6 | | | 8.6 | 8.4 | | 6.9/38.7m | 8.5 | 8.2 | | 40.0 |
| 42.0 | | | 8.3 | | | 8.6/40.2m | 8.1 | | | 8.1 | 7.9 | | | 8.0 | 7.7 | | 42.0 |
| 44.0 | | | 7.8 | 7.0/44.2m | | 7.6 | | | | 7.8/43.2m | 7.4 | | | 7.5 | 7.2 | | 44.0 |
| 46.0 | | | 7.7/44.4m | 6.7 | | 7.2 | 6.4/46.4m | | | 7.0 | | | | 7.1 | 6.8 | | 46.0 |
| 48.0 | | | | 6.4 | | | 6.9/47.3m | 6.2 | | | 6.6 | 5.9/48.5m | | 7.1/46.1m | 6.4 | | 48.0 |
| 50.0 | | | | 6.1 | | | | 5.9 | | | 6.2 | 5.7 | | | 6.0 | 5.3/50.7m | 50.0 |
| 52.0 | | | | 5.9/51.0m | | | | 5.6 | | | 6.2/50.2m | 5.4 | | | 5.7 | 5.2 | 52.0 |
| 54.0 | | | | | | | | 5.3/53.9m | | | | 5.1 | | | 5.5/53.2m | 4.9 | 54.0 |
| 56.0 | | | | | | | | | | | | 4.8 | | | | 4.6 | 56.0 |
| 58.0 | | | | | | | | | | | | 4.6/56.8m | | | | 4.3 | 58.0 |
| 60.0 | | | | | | | | | | | | | | | | 4.0/59.8m | 60.0 |

※表中の太線で囲まれた部分は、ブーム等の強度によって定められた値です。
ジブ長さ27.4mでの、ボールフックの使用はできません。

▶ タワー長さ45.8m (75.1tカウンタウエイト/カーボディウエイトなし)(オプション)

(単位:t)

| タワー長さm | 45.8 | | | | | | | | | | | | | | | | タワー長さm | | | | | |
|--------|------------|------------|------------|-----------|------------|------------|-----------|-----|------------|------------|-----------|-----|------------|------------|-----------|-----|------------|------------|-----------|-----|-----------|------|
| ジブ長さm | 27.4 | | | | 30.5 | | | | 33.5 | | | | 36.6 | | | | 39.6 | | | | ジブ長さm | |
| タワー角度 | 90° | 80° | 70° | 60° | 90° | 80° | 70° | 60° | 90° | 80° | 70° | 60° | 90° | 80° | 70° | 60° | 90° | 80° | 70° | 60° | タワー角度 | |
| 10.0 | 25.0/10.9m | | | | 24.4/11.7m | | | | | | | | | | | | | | | | 10.0 | |
| 12.0 | 25.0 | | | | 24.2 | | | | 22.7/12.5m | | | | 21.0/13.3m | | | | | | | | 12.0 | |
| 14.0 | 25.0 | | | | 23.8 | | | | 22.3 | | | | 20.8 | | | | 19.3/14.1m | | | | 14.0 | |
| 16.0 | 24.6 | | | | 23.4 | | | | 21.9 | | | | 20.4 | | | | 18.9 | | | | 16.0 | |
| 18.0 | 24.2 | | | | 23.0 | | | | 21.5 | | | | 20.0 | | | | 18.5 | | | | 18.0 | |
| 20.0 | 23.8 | | | | 22.6 | | | | 21.1 | | | | 19.6 | | | | 18.1 | | | | 20.0 | |
| 22.0 | 23.1 | 17.3/23.3m | | | 22.2 | | | | 20.7 | | | | 19.2 | | | | 17.7 | | | | 22.0 | |
| 24.0 | 19.9 | 16.3 | | | 20.3 | 16.0/24.6m | | | 20.3 | 14.8/25.9m | | | 18.8 | | | | 17.3 | | | | 24.0 | |
| 26.0 | 17.1 | 14.8 | | | 17.7 | 14.7 | | | 18.0 | 14.6 | | | 18.3 | 13.8/27.2m | | | 16.9 | | | | 26.0 | |
| 28.0 | 14.1 | 13.4 | | | 15.5 | 13.3 | | | 15.9 | 13.2 | | | 16.2 | 13.1 | | | 16.5 | 12.9/28.5m | | | 28.0 | |
| 30.0 | 10.2/29.9m | 12.3 | | | 13.4 | 12.2 | | | 14.0 | 12.1 | | | 14.4 | 12.0 | | | 14.6 | 11.9 | | | 30.0 | |
| 32.0 | | 11.4 | | | 10.5 | 11.3 | | | 12.3 | 11.2 | | | 12.8 | 11.1 | | | 13.0 | 11.0 | | | 32.0 | |
| 34.0 | | 10.6 | 10.2/35.0m | | 8.9/32.8m | 10.5 | | | 10.3 | 10.4 | | | 11.4 | 10.3 | | | 11.7 | 10.2 | | | 34.0 | |
| 36.0 | | 9.9 | 9.9 | | | 9.8 | 9.5/36.8m | | 7.8/35.8m | 9.7 | | | 10.0 | 9.6 | | | 10.5 | 9.5 | | | 36.0 | |
| 38.0 | | 9.3/37.8m | 9.3 | | | 9.2 | 9.1 | | 9.1 | 8.5/38.5m | | | 8.0 | 9.0 | | | 9.4 | 8.9 | | | 38.0 | |
| 40.0 | | | 8.8 | | | 8.7 | 8.6 | | | 8.6 | 8.4 | | 6.9/38.7m | 8.5 | 8.2/40.3m | | 8.0 | 8.4 | | | 40.0 | |
| 42.0 | | | 8.3 | | | 8.4/40.7m | 8.1 | | | 8.1 | 7.9 | | | 8.0 | 7.7 | | 6.1/41.7m | 7.9 | 7.6 | | 42.0 | |
| 44.0 | | | 7.8 | 6.6/45.8m | | 7.6 | | | 7.8/43.7m | 7.4 | | | | 7.5 | 7.2 | | | 7.4 | 7.1 | | 44.0 | |
| 46.0 | | | 7.5/45.4m | 6.5 | | 7.2 | 6.1/47.9m | | | 7.0 | | | | 7.1 | 6.8 | | | 7.0 | 6.7 | | 46.0 | |
| 48.0 | | | | 6.2 | | 6.8 | 6.1 | | | 6.6 | | | | 7.0/46.6m | 6.4 | | | 6.6 | 6.3 | | 48.0 | |
| 50.0 | | | | 5.9 | | 6.7/48.3m | 5.8 | | | 6.2 | 5.5/50.1m | | | 6.0 | | | 6.4/49.6m | 5.9 | | | 50.0 | |
| 52.0 | | | | 5.6 | | | 5.5 | | | 6.0/51.3m | 5.3 | | | 5.7 | 5.0/52.2m | | | 5.6 | | | 52.0 | |
| 54.0 | | | | 5.5/52.5m | | | 5.2 | | | | 5.0 | | | 5.5 | 4.8 | | | 5.4 | 4.6/54.4m | | 54.0 | |
| 56.0 | | | | | | | 4.9/55.4m | | | | 4.8 | | | 5.4/54.2m | 4.6 | | | | 5.1 | 4.4 | 56.0 | |
| 58.0 | | | | | | | | | | | 4.5 | | | | | | 4.4 | | 4.8/57.2m | 4.2 | 58.0 | |
| 60.0 | | | | | | | | | | | 4.4/58.4m | | | | | | 4.2 | | | 4.0 | 60.0 | |
| 62.0 | | | | | | | | | | | | | | | | | 4.0/61.3m | | | | 62.0 | |
| 64.0 | | | | | | | | | | | | | | | | | | | | | 64.0 | |
| 66.0 | | | | | | | | | | | | | | | | | | | | | 3.5/64.3m | 66.0 |

※表中の太線で囲まれた部分は、ブーム等の強度によって定められた値です。
ジブ長さ27.4mでの、ボールフックの使用はできません。

▶ タワー長さ48.8m (75.1tカウンタウエイト/カーボディウエイトなし)(オプション)

(単位:t)

| タワー長さm | 48.8 | | | | | | | | | | | | タワー長さm |
|---------|------|------------|------------|-----------|------------|------------|-----------|-----------|------|-----|-----|-----------|--------|
| ジブ長さm | 27.4 | | | | 30.5 | | | | 33.5 | | | | ジブ長さm |
| タワー角度 | 90° | 80° | 70° | 60° | 90° | 80° | 70° | 60° | 90° | 80° | 70° | 60° | タワー角度 |
| 作業半径(m) | 10.0 | 25.0/10.9m | | | 24.4/11.7m | | | | | | | | 10.0 |
| | 12.0 | 25.0 | | | 24.2 | | | | | | | | 12.0 |
| | 14.0 | 25.0 | | | 23.8 | | | | | | | | 14.0 |
| | 16.0 | 24.6 | | | 23.4 | | | | | | | | 16.0 |
| | 18.0 | 24.2 | | | 23.0 | | | | | | | | 18.0 |
| | 20.0 | 23.8 | | | 22.6 | | | | | | | | 20.0 |
| | 22.0 | 23.1 | 16.6/23.9m | | 22.2 | | | | | | | | 22.0 |
| | 24.0 | 19.9 | 16.3 | | 20.3 | 15.4/25.1m | | | | | | | 24.0 |
| | 26.0 | 17.1 | 14.8 | | 17.7 | 14.7 | | | | | | | 26.0 |
| | 28.0 | 14.1 | 13.4 | | 15.5 | 13.3 | | | | | | | 28.0 |
| | 30.0 | 10.2/29.9m | 12.3 | | 13.4 | 12.2 | | | | | | | 30.0 |
| | 32.0 | | 11.4 | | 10.5 | 11.3 | | | | | | | 32.0 |
| | 34.0 | | 10.6 | | 8.9/32.8m | 10.5 | | | | | | | 34.0 |
| | 36.0 | | 9.9 | 9.9/36.1m | | 9.8 | 9.2/37.8m | | | | | | 36.0 |
| | 38.0 | | 9.3 | 9.3 | | 9.2 | 9.1 | | | | | | 38.0 |
| | 40.0 | | 9.2/38.3m | 8.8 | | 8.7 | 8.6 | | | | | | 40.0 |
| | 42.0 | | | 8.3 | | 8.4/41.3m | 8.1 | | | | | | 42.0 |
| | 44.0 | | | 7.8 | | | 7.6 | | | | | | 44.0 |
| | 46.0 | | | 7.4 | 5.9/47.3m | | 7.2 | | | | | | 46.0 |
| | 48.0 | | | 7.3/46.4m | 5.9 | | 6.8 | 5.3/49.4m | | | | | 48.0 |
| 50.0 | | | | 5.6 | | 6.5/49.4m | 5.2 | | | | | 50.0 | |
| 52.0 | | | | 5.3 | | | 5.0 | | | | | 52.0 | |
| 54.0 | | | | 5.0 | | | 4.8 | | | | | 54.0 | |
| 56.0 | | | | | | | 4.6 | | | | | 56.0 | |
| 58.0 | | | | | | | 4.5/56.9m | | | | | 58.0 | |
| 60.0 | | | | | | | | | | | | 4.1/59.9m | 60.0 |

※表中の太線で囲まれた部分は、ブーム等の強度によって定められた値です。
ジブ長さ27.4mでの、ボールフックの使用はできません。

(単位:t)

| タワー長さm | 48.8 | | | | | | | | | | | | タワー長さm |
|---------|------|------------|------------|-----------|------------|------------|-----------|-----------|------------|------------|-----------|------|--------|
| ジブ長さm | 36.6 | | | | 39.6 | | | | 42.7 | | | | ジブ長さm |
| タワー角度 | 90° | 80° | 70° | 60° | 90° | 80° | 70° | 60° | 90° | 80° | 70° | 60° | タワー角度 |
| 作業半径(m) | 12.0 | 21.0/13.3m | | | | | | | | | | | 12.0 |
| | 14.0 | 20.8 | | | 19.3/14.1m | | | | 17.7/14.9m | | | | 14.0 |
| | 16.0 | 20.4 | | | 18.9 | | | | 17.3 | | | | 16.0 |
| | 18.0 | 20.0 | | | 18.5 | | | | 16.9 | | | | 18.0 |
| | 20.0 | 19.6 | | | 18.1 | | | | 16.5 | | | | 20.0 |
| | 22.0 | 19.2 | | | 17.7 | | | | 16.1 | | | | 22.0 |
| | 24.0 | 18.8 | | | 17.3 | | | | 15.7 | | | | 24.0 |
| | 26.0 | 18.3 | 13.4/27.7m | | 16.9 | | | | 15.3 | | | | 26.0 |
| | 28.0 | 16.2 | 13.1 | | 16.5 | 12.5/29.0m | | | 14.9 | | | | 28.0 |
| | 30.0 | 14.4 | 12.0 | | 14.6 | 11.9 | | | 14.5 | 11.8/30.3m | | | 30.0 |
| | 32.0 | 12.8 | 11.1 | | 13.0 | 11.0 | | | 13.1 | 10.9 | | | 32.0 |
| | 34.0 | 11.4 | 10.3 | | 11.7 | 10.2 | | | 11.8 | 10.1 | | | 34.0 |
| | 36.0 | 10.0 | 9.6 | | 10.5 | 9.5 | | | 10.6 | 9.4 | | | 36.0 |
| | 38.0 | 8.0 | 9.0 | | 9.4 | 8.9 | | | 9.5 | 8.8 | | | 38.0 |
| | 40.0 | 6.9/38.7m | 8.5 | 7.9/41.3m | 8.0 | 8.4 | | | 8.6 | 8.3 | | | 40.0 |
| | 42.0 | | 8.0 | 7.7 | 6.1/41.7m | 7.9 | 7.3/43.1m | | 7.6 | 7.8 | | | 42.0 |
| | 44.0 | | 7.5 | 7.2 | | 7.4 | 7.1 | | 6.1 | 7.3 | 6.8/44.8m | | 44.0 |
| | 46.0 | | 7.1 | 6.8 | | 7.0 | 6.7 | | 5.3/44.6m | 6.9 | 6.6 | | 46.0 |
| | 48.0 | | 6.8/47.2m | 6.4 | | 6.6 | 6.3 | | | 6.5 | 6.2 | | 48.0 |
| | 50.0 | | | 6.0 | | 6.3 | 5.9 | | | 6.2 | 5.8 | | 50.0 |
| 52.0 | | | 5.7 | 4.6/53.7m | 6.3/50.1m | 5.6 | | | 5.9 | 5.5 | | 52.0 | |
| 54.0 | | | 5.5 | 4.6 | | 5.4 | 4.3/55.9m | | 5.8/53.0m | 5.3 | | 54.0 | |
| 56.0 | | | 5.3/55.3m | 4.4 | | 5.1 | 4.3 | | | 5.0 | | 56.0 | |
| 58.0 | | | | 4.2 | | 4.8 | 4.1 | | | 4.7 | 4.0/58.1m | 58.0 | |
| 60.0 | | | | 4.0 | | 4.8/58.2m | 3.9 | | | 4.5 | 3.8 | 60.0 | |
| 62.0 | | | | 3.8 | | | 3.7 | | | 4.3/61.2m | 3.6 | 62.0 | |
| 64.0 | | | | 3.7/62.8m | | | | | | | 3.4 | 64.0 | |
| 66.0 | | | | | | | | 3.3/65.8m | | | 3.2 | 66.0 | |
| 68.0 | | | | | | | | | | | 3.0 | 68.0 | |
| 70.0 | | | | | | | | | | | 2.9/68.7m | 70.0 | |

※表中の太線で囲まれた部分は、ブーム等の強度によって定められた値です。

▶ タワー長さ51.9m (75.1tカウンタウエイト/カーボディウエイトなし)(オプション)

(単位:t)

| タワー長さm | 51.9 | | | | | | | | | | | | | | | | タワー長さm | |
|---------|------|------------|------------|-----------|------------|------------|-----------|-----------|------|------------|------------|-----------|-----------|-----|------------|------------|-----------|------|
| ジブ長さm | 27.4 | | | | 30.5 | | | | 33.5 | | | | 36.6 | | | | ジブ長さm | |
| タワー角度 | 90° | 80° | 70° | 60° | 90° | 80° | 70° | 60° | 90° | 80° | 70° | 60° | 90° | 80° | 70° | 60° | タワー角度 | |
| 作業半径(m) | 10.0 | 25.0/10.9m | | | 24.4/11.7m | | | | | | | | | | | 10.0 | | |
| | 12.0 | 25.0 | | | 24.2 | | | | | 22.7/12.5m | | | | | 21.0/13.3m | 12.0 | | |
| | 14.0 | 25.0 | | | 23.8 | | | | | 22.3 | | | | | 20.8 | 14.0 | | |
| | 16.0 | 24.6 | | | 23.4 | | | | | 21.9 | | | | | 20.4 | 16.0 | | |
| | 18.0 | 24.2 | | | 23.0 | | | | | 21.5 | | | | | 20.0 | 18.0 | | |
| | 20.0 | 23.8 | | | 22.6 | | | | | 21.1 | | | | | 19.6 | 20.0 | | |
| | 22.0 | 23.1 | | | 22.2 | | | | | 20.7 | | | | | 19.2 | 22.0 | | |
| | 24.0 | 19.9 | 16.2/24.4m | | 20.3 | 15.1/25.7m | | | | 20.3 | | | | | 18.8 | 24.0 | | |
| | 26.0 | 17.1 | 14.8 | | 17.7 | 14.7 | | | | 18.0 | 14.0/27.0m | | | | 18.3 | 26.0 | | |
| | 28.0 | 14.1 | 13.4 | | 15.5 | 13.3 | | | | 15.9 | 13.2 | | | | 16.2 | 13.1/28.2m | 28.0 | |
| | 30.0 | 10.2/29.9m | 12.3 | | 13.4 | 12.2 | | | | 14.0 | 12.1 | | | | 14.4 | 12.0 | 30.0 | |
| | 32.0 | | 11.4 | | 10.5 | 11.3 | | | | 12.3 | 11.2 | | | | 12.8 | 11.1 | 32.0 | |
| | 34.0 | | 10.6 | | 8.9/32.8m | 10.5 | | | | 10.3 | 10.4 | | | | 11.4 | 10.3 | 34.0 | |
| | 36.0 | | 9.9 | 9.6/37.1m | | 9.8 | | | | 7.8/35.8m | 9.7 | | | | 10.0 | 9.6 | 36.0 | |
| | 38.0 | | 9.3 | 9.3 | | 9.2 | 8.9/38.9m | | | | 9.1 | | | | 8.0 | 9.0 | 38.0 | |
| | 40.0 | | 8.8/38.9m | 8.8 | | 8.7 | 8.6 | | | | 8.6 | 8.3/40.6m | | | 6.9/38.7m | 8.5 | 40.0 | |
| | 42.0 | | | 8.3 | | 8.3/41.8m | 8.1 | | | | 8.1 | 7.9 | | | 8.0 | 7.9/42.4m | 42.0 | |
| | 44.0 | | | 7.8 | | | 7.6 | | | | 7.6 | 7.4 | | | 7.5 | 7.7 | 44.0 | |
| | 46.0 | | | 7.4 | | | 7.2 | | | | 7.4/44.7m | 7.0 | | | 7.1 | 7.2 | 46.0 | |
| | 48.0 | | | 7.1/47.5m | 5.4/48.8m | | 6.8 | | | | | 6.6 | | | 6.8/47.7m | 6.8 | 48.0 | |
| | 50.0 | | | | 5.3 | | 6.4 | 4.9/51.0m | | | | 6.2 | | | | 6.4 | 50.0 | |
| | 52.0 | | | | 5.1 | | 6.3/50.4m | 4.8 | | | | 5.9 | 4.5/53.1m | | | 6.0 | 52.0 | |
| | 54.0 | | | | 4.9 | | | 4.6 | | | | 5.7/53.4m | 4.4 | | | 5.7 | 4.2/55.3m | 54.0 |
| | 56.0 | | | | 4.7/55.5m | | | 4.4 | | | | | 4.2 | | | 5.5 | 4.1 | 56.0 |
| 58.0 | | | | | | | 4.2 | | | | | 4.0 | | | 5.1/56.3m | 3.9 | 58.0 | |
| 60.0 | | | | | | | 4.1/58.5m | | | | | 3.8 | | | | 3.7 | 60.0 | |
| 62.0 | | | | | | | | | | | | 3.5/61.4m | | | | 3.5 | 62.0 | |
| 64.0 | | | | | | | | | | | | | | | | 3.3 | 64.0 | |
| 66.0 | | | | | | | | | | | | | | | | 3.2/64.4m | 66.0 | |

※表中の太線で囲まれた部分は、ブーム等の強度によって定められた値です。
ジブ長さ27.4mでの、ボールフックの使用はできません。

(単位:t)

| タワー長さm | 51.9 | | | | | | | | | | | | タワー長さm |
|---------|------|------------|------------|-----------|------------|------------|-----------|-----------|------------|------------|-----------|-----------|--------|
| ジブ長さm | 39.6 | | | | 42.7 | | | | 45.7 | | | | ジブ長さm |
| タワー角度 | 90° | 80° | 70° | 60° | 90° | 80° | 70° | 60° | 90° | 80° | 70° | 60° | タワー角度 |
| 作業半径(m) | 14.0 | 19.3/14.1m | | | 17.7/14.9m | | | | 15.6/15.7m | | | | 14.0 |
| | 16.0 | 18.9 | | | 17.3 | | | | 15.5 | | | | 16.0 |
| | 18.0 | 18.5 | | | 16.9 | | | | 15.1 | | | | 18.0 |
| | 20.0 | 18.1 | | | 16.5 | | | | 14.7 | | | | 20.0 |
| | 22.0 | 17.7 | | | 16.1 | | | | 14.3 | | | | 22.0 |
| | 24.0 | 17.3 | | | 15.7 | | | | 13.9 | | | | 24.0 |
| | 26.0 | 16.9 | | | 15.3 | | | | 13.5 | | | | 26.0 |
| | 28.0 | 16.5 | 12.2/29.5m | | 14.9 | | | | 13.1 | | | | 28.0 |
| | 30.0 | 14.6 | 11.9 | | 14.5 | 11.5/30.8m | | | 12.7 | | | | 30.0 |
| | 32.0 | 13.0 | 11.0 | | 13.1 | 10.9 | | | 12.3 | 10.8/32.1m | | | 32.0 |
| | 34.0 | 11.7 | 10.2 | | 11.8 | 10.1 | | | 11.9 | 10.0 | | | 34.0 |
| | 36.0 | 10.5 | 9.5 | | 10.6 | 9.4 | | | 10.7 | 9.3 | | | 36.0 |
| | 38.0 | 9.4 | 8.9 | | 9.5 | 8.8 | | | 9.7 | 8.7 | | | 38.0 |
| | 40.0 | 8.0 | 8.4 | | 8.6 | 8.3 | | | 8.8 | 8.2 | | | 40.0 |
| | 42.0 | 6.1/41.7m | 7.9 | | 7.6 | 7.8 | | | 7.9 | 7.7 | | | 42.0 |
| | 44.0 | | 7.4 | 7.1/44.1m | 6.1 | 7.3 | 6.7/45.9m | | 7.1 | 7.2 | | | 44.0 |
| | 46.0 | | 7.0 | 6.7 | 5.3/44.6m | 6.9 | 6.6 | | 6.1 | 6.8 | 6.2/47.6m | | 46.0 |
| | 48.0 | | 6.6 | 6.3 | | 6.5 | 6.2 | | 4.7/47.5m | 6.4 | 6.1 | | 48.0 |
| | 50.0 | | 6.3 | 5.9 | | 6.2 | 5.8 | | | 6.1 | 5.7 | | 50.0 |
| | 52.0 | | 6.2/50.6m | 5.6 | | 5.9 | 5.5 | | | 5.8 | 5.5 | | 52.0 |
| | 54.0 | | | 5.4 | | 5.7/53.6m | 5.3 | | | 5.5 | 5.2 | | 54.0 |
| | 56.0 | | | 5.1 | 3.9/57.4m | | 5.0 | | | 5.2 | 4.9 | | 56.0 |
| | 58.0 | | | 4.8 | 3.8 | | 4.7 | 3.5/59.6m | | 5.1/56.5m | 4.6 | | 58.0 |
| | 60.0 | | | 4.6/59.3m | 3.6 | | 4.5 | 3.4 | | | 4.4 | 3.0/61.7m | 60.0 |
| 62.0 | | | | 3.4 | | 4.3 | 3.2 | | | 4.2 | 3.0 | 62.0 | |
| 64.0 | | | | 3.2 | | 4.2/62.2m | 3.0 | | | 4.0 | 2.8 | 64.0 | |
| 66.0 | | | | 3.0 | | | 2.8 | | | 3.9/65.2m | 2.6 | 66.0 | |
| 68.0 | | | | 2.7/67.3m | | | 2.6 | | | | 2.4 | 68.0 | |
| 70.0 | | | | | | | 2.4 | | | | | 70.0 | |

※表中の太線で囲まれた部分は、ブーム等の強度によって定められた値です。

▶ タワー長さ54.9m (75.1tカウンタウエイト/カーボディウエイトなし)(オプション)

(単位:t)

| タワー長さm | 54.9 | | | | | | | | | | | | | | | | タワー長さm | | |
|--------|------------|------------|-----------|-----------|------------|------------|-----------|-----------|------|-----|-----|------------|------------|-----------|-----|------------|------------|-----------|------|
| ジブ長さm | 27.4 | | | | 30.5 | | | | 33.5 | | | | 36.6 | | | | ジブ長さm | | |
| タワー角度 | 90° | 80° | 70° | 60° | 90° | 80° | 70° | 60° | 90° | 80° | 70° | 60° | 90° | 80° | 70° | 60° | タワー角度 | | |
| 10.0 | 25.0/10.9m | | | | 24.4/11.7m | | | | | | | | | | | | 10.0 | | |
| 12.0 | 25.0 | | | | 24.2 | | | | | | | 22.7/12.5m | | | | 21.0/13.3m | 12.0 | | |
| 14.0 | 25.0 | | | | 23.8 | | | | | | | 22.3 | | | | 20.8 | 14.0 | | |
| 16.0 | 24.6 | | | | 23.4 | | | | | | | 21.9 | | | | 20.4 | 16.0 | | |
| 18.0 | 24.2 | | | | 23.0 | | | | | | | 21.5 | | | | 20.0 | 18.0 | | |
| 20.0 | 23.8 | | | | 22.6 | | | | | | | 21.1 | | | | 19.6 | 20.0 | | |
| 22.0 | 23.1 | | | | 22.2 | | | | | | | 20.7 | | | | 19.2 | 22.0 | | |
| 24.0 | 19.9 | 15.6/24.9m | | | 20.3 | | | | | | | 20.3 | | | | 18.8 | 24.0 | | |
| 26.0 | 17.1 | 14.8 | | | 17.7 | 14.7/26.2m | | | | | | 18.0 | 13.7/27.5m | | | 18.3 | 26.0 | | |
| 28.0 | 14.1 | 13.4 | | | 15.5 | 13.3 | | | | | | 15.9 | 13.2 | | | 16.2 | 12.8/28.8m | 28.0 | |
| 30.0 | 10.2/29.9m | 12.3 | | | 13.4 | 12.2 | | | | | | 14.0 | 12.1 | | | 14.4 | 12.0 | 30.0 | |
| 32.0 | | 11.4 | | | 10.5 | 11.3 | | | | | | 12.3 | 11.2 | | | 12.8 | 11.1 | 32.0 | |
| 34.0 | | 10.6 | | | 8.9/32.8m | 10.5 | | | | | | 10.3 | 10.4 | | | 11.4 | 10.3 | 34.0 | |
| 36.0 | | 9.9 | | | | 9.8 | | | | | | 7.8/35.8m | 9.7 | | | 10.0 | 9.6 | 36.0 | |
| 38.0 | | 9.3 | 9.3/38.2m | | | 9.2 | 8.9/39.9m | | | | | 9.1 | | | | 8.0 | 9.0 | 38.0 | |
| 40.0 | | 8.9/39.4m | 8.8 | | | 8.7 | 8.6 | | | | | 8.6 | 8.0/41.7m | | | 6.9/38.7m | 8.5 | 40.0 | |
| 42.0 | | | 8.3 | | | 8.2 | 8.1 | | | | | 8.1 | 7.9 | | | 8.0 | 7.4/43.4m | 42.0 | |
| 44.0 | | | 7.8 | | | 8.0/42.3m | 7.6 | | | | | 7.6 | 7.4 | | | 7.5 | 7.2 | 44.0 | |
| 46.0 | | | 7.4 | | | | 7.2 | | | | | 7.3/45.3m | 7.0 | | | 7.1 | 6.8 | 46.0 | |
| 48.0 | | | 7.0 | | | | 6.8 | | | | | | 6.6 | | | 6.7 | 6.4 | 48.0 | |
| 50.0 | | | 6.9/48.5m | 5.1/50.3m | | | 6.4 | | | | | | 6.2 | | | 6.7/48.2m | 6.0 | 50.0 | |
| 52.0 | | | | 4.9 | | | 6.2/51.5m | 4.6/52.5m | | | | | 5.9 | | | | 5.7 | 52.0 | |
| 54.0 | | | | 4.7 | | | | 4.4 | | | | | 5.7 | 4.2/54.6m | | | 5.5 | 54.0 | |
| 56.0 | | | | 4.5 | | | | 4.2 | | | | | 5.6/54.4m | 4.0 | | | 5.2 | 3.7/56.8m | 56.0 |
| 58.0 | | | | 4.4/57.0m | | | | 4.0 | | | | | | 3.8 | | | 5.0/57.4m | 3.5 | 58.0 |
| 60.0 | | | | | | | | 3.8 | | | | | | 3.5 | | | | 3.3 | 60.0 |
| 62.0 | | | | | | | | | | | | | | 3.3 | | | | 3.1 | 62.0 |
| 64.0 | | | | | | | | | | | | | | 3.0/62.9m | | | | 2.9 | 64.0 |
| 66.0 | | | | | | | | | | | | | | | | | | 2.7/65.9m | 66.0 |

※表中の太線で囲まれた部分は、ブーム等の強度によって定められた値です。
ジブ長さ27.4mでの、ボールフックの使用はできません。

(単位:t)

| タワー長さm | 54.9 | | | | | | | | | | | | タワー長さm | | | | |
|--------|------------|------------|-----------|-----------|------------|------------|-----------|-----------|------------|------------|-----------|-----|------------|------------|-----------|-----|-------|
| ジブ長さm | 39.6 | | | | 42.7 | | | | 45.7 | | | | 48.8 | | | | ジブ長さm |
| タワー角度 | 90° | 80° | 70° | 60° | 90° | 80° | 70° | 60° | 90° | 80° | 70° | 60° | 90° | 80° | 70° | 60° | タワー角度 |
| 14.0 | 19.3/14.1m | | | | 17.7/14.9m | | | | 15.6/15.7m | | | | | | | | 14.0 |
| 16.0 | 18.9 | | | | 17.3 | | | | 15.5 | | | | 13.8/16.5m | | | | 16.0 |
| 18.0 | 18.5 | | | | 16.9 | | | | 15.1 | | | | 13.4 | | | | 18.0 |
| 20.0 | 18.1 | | | | 16.5 | | | | 14.7 | | | | 13.0 | | | | 20.0 |
| 22.0 | 17.7 | | | | 16.1 | | | | 14.3 | | | | 12.6 | | | | 22.0 |
| 24.0 | 17.3 | | | | 15.7 | | | | 13.9 | | | | 12.2 | | | | 24.0 |
| 26.0 | 16.9 | | | | 15.3 | | | | 13.5 | | | | 11.8 | | | | 26.0 |
| 28.0 | 16.5 | | | | 14.9 | | | | 13.1 | | | | 11.4 | | | | 28.0 |
| 30.0 | 14.6 | 11.9/30.1m | | | 14.5 | 11.5/31.4m | | | 12.7 | | | | 11.0 | | | | 30.0 |
| 32.0 | 13.0 | 11.0 | | | 13.1 | 10.9 | | | 12.3 | 10.7/32.6m | | | 10.6 | 10.0/33.9m | | | 32.0 |
| 34.0 | 11.7 | 10.2 | | | 11.8 | 10.1 | | | 11.9 | 10.0 | | | 10.2 | 9.9 | | | 34.0 |
| 36.0 | 10.5 | 9.5 | | | 10.6 | 9.4 | | | 10.7 | 9.3 | | | 9.8 | 9.2 | | | 36.0 |
| 38.0 | 9.4 | 8.9 | | | 9.5 | 8.8 | | | 9.7 | 8.7 | | | 9.4 | 8.6 | | | 38.0 |
| 40.0 | 8.0 | 8.4 | | | 8.6 | 8.3 | | | 8.8 | 8.2 | | | 8.9 | 8.1 | | | 40.0 |
| 42.0 | 6.1/41.7m | 7.9 | | | 7.6 | 7.8 | | | 7.9 | 7.7 | | | 8.0 | 7.6 | | | 42.0 |
| 44.0 | | 7.4 | 6.9/45.2m | | 6.1 | 7.3 | | | 7.1 | 7.2 | | | 7.3 | 7.1 | | | 44.0 |
| 46.0 | | 7.0 | 6.7 | | 5.3/44.6m | 6.9 | 6.3/46.9m | | 6.1 | 6.8 | | | 6.6 | 6.7 | | | 46.0 |
| 48.0 | | 6.6 | 6.3 | | | 6.5 | 6.2 | 4.7/47.5m | 6.4 | 6.0/48.7m | | | 5.8 | 6.3 | | | 48.0 |
| 50.0 | | 6.3 | 5.9 | | | 6.2 | 5.8 | | 6.1 | 5.7 | | | 4.7 | 6.0 | 5.6/50.4m | | 50.0 |
| 52.0 | | 6.2/51.2m | 5.6 | | | 5.9 | 5.5 | | 5.8 | 5.4 | 4.1/50.5m | | 5.7 | 5.3 | | | 52.0 |
| 54.0 | | | 5.4 | | | 5.6 | 5.3 | | 5.5 | 5.2 | | | 5.4 | 5.0 | | | 54.0 |
| 56.0 | | | 5.1 | | | 5.6/54.1m | 5.0 | | 5.2 | 4.9 | | | 5.1 | 4.7 | | | 56.0 |
| 58.0 | | | 4.8 | 3.2/58.9m | | | 4.7 | | 5.0/57.0m | 4.6 | | | 4.9 | 4.4 | | | 58.0 |
| 60.0 | | | 4.6 | 3.1 | | | 4.5 | | | 4.4 | | | 4.6 | 4.2 | | | 60.0 |
| 62.0 | | | 4.5/60.3m | 2.9 | | | 4.3 | | | 4.2 | | | | 3.9 | | | 62.0 |
| 64.0 | | | | 2.7 | | | 4.1/63.3m | | | 4.0 | | | | 3.7 | | | 64.0 |
| 66.0 | | | | 2.5 | | | | | | 3.8 | | | | 3.5 | | | 66.0 |
| 68.0 | | | | | | | | | | 3.7/66.2m | | | | 3.3 | | | 68.0 |
| 70.0 | | | | | | | | | | | | | | 3.3/69.1m | | | 70.0 |

※表中の太線で囲まれた部分は、ブーム等の強度によって定められた値です。

▶ タワー長さ58.0m (75.1tカウンタウエイト/カーボディウエイトなし)(オプション)

(単位:t)

| タワー長さm | 58.0 | | | | | | | | | | | | | | | | | | タワー長さm |
|--------|------------|------------|-----------|-----------|------------|------------|-----------|-----------|------|-----|------------|-----------|-----|------------|------------|-----|------------|-------|--------|
| ジブ長さm | 27.4 | | | | 30.5 | | | | 33.5 | | | 36.6 | | | 39.6 | | | ジブ長さm | |
| タワー角度 | 90° | 80° | 70° | 60° | 90° | 80° | 70° | 60° | 90° | 80° | 70° | 90° | 80° | 70° | 90° | 80° | 70° | タワー角度 | |
| 10.0 | 25.0/10.9m | | | | 24.4/11.7m | | | | | | | | | | | | | 10.0 | |
| 12.0 | 25.0 | | | | 24.2 | | | | | | 22.7/12.5m | | | 21.0/13.3m | | | | 12.0 | |
| 14.0 | 25.0 | | | | 23.8 | | | | | | 22.3 | | | 20.8 | | | 19.3/14.1m | 14.0 | |
| 16.0 | 24.6 | | | | 23.4 | | | | | | 21.9 | | | 20.4 | | | 18.9 | 16.0 | |
| 18.0 | 24.2 | | | | 23.0 | | | | | | 21.5 | | | 20.0 | | | 18.5 | 18.0 | |
| 20.0 | 23.8 | | | | 22.6 | | | | | | 21.1 | | | 19.6 | | | 18.1 | 20.0 | |
| 22.0 | 23.1 | | | | 22.2 | | | | | | 20.7 | | | 19.2 | | | 17.7 | 22.0 | |
| 24.0 | 19.9 | 15.3/25.4m | | | 20.3 | | | | | | 20.3 | | | 18.8 | | | 17.3 | 24.0 | |
| 26.0 | 17.1 | 14.8 | | | 17.7 | 14.4/26.7m | | | | | 18.0 | | | 18.3 | | | 16.9 | 26.0 | |
| 28.0 | 14.1 | 13.4 | | | 15.5 | 13.3 | | | | | 15.9 | 13.2 | | 16.2 | 12.5/29.3m | | 16.5 | 28.0 | |
| 30.0 | 10.2/29.9m | 12.3 | | | 13.4 | 12.2 | | | | | 14.0 | 12.1 | | 14.4 | 12.0 | | 14.6 | 30.0 | |
| 32.0 | | 11.4 | | | 10.5 | 11.3 | | | | | 12.3 | 11.2 | | 12.8 | 11.1 | | 13.0 | 32.0 | |
| 34.0 | | 10.6 | | | 8.9/32.8m | 10.5 | | | | | 10.3 | 10.4 | | 11.4 | 10.3 | | 11.7 | 34.0 | |
| 36.0 | | 9.9 | | | | 9.8 | | | | | 7.8/35.8m | 9.7 | | 10.0 | 9.6 | | 10.5 | 36.0 | |
| 38.0 | | 9.3 | 9.0/39.2m | | | 9.2 | | | | | 9.1 | | | 8.0 | 9.0 | | 9.4 | 38.0 | |
| 40.0 | | 8.7/39.9m | 8.8 | | | 8.7 | 8.4/41.0m | | | | 8.6 | | | 6.9/38.7m | 8.5 | | 8.0 | 40.0 | |
| 42.0 | | | 8.3 | | | 8.2 | 8.1 | | | | 8.1 | 7.8/42.7m | | 8.0 | | | 6.1/41.7m | 42.0 | |
| 44.0 | | | 7.8 | | | 8.0/42.9m | 7.6 | | | | 7.6 | 7.4 | | 7.5 | 7.1/44.5m | | 7.4 | 44.0 | |
| 46.0 | | | 7.4 | | | | 7.2 | | | | 7.1/45.8m | 7.0 | | 7.1 | 6.8 | | 7.0 | 46.0 | |
| 48.0 | | | 7.0 | | | | 6.8 | | | | | 6.6 | | 6.7 | 6.4 | | 6.6 | 48.0 | |
| 50.0 | | | 6.7/49.6m | 4.4/51.8m | | | 6.4 | | | | | 6.2 | | 6.6/48.7m | 6.0 | | 6.3 | 50.0 | |
| 52.0 | | | | 4.3 | | | 6.1 | | | | | 5.9 | | | 5.7 | | 6.1/51.7m | 52.0 | |
| 54.0 | | | | 4.2 | | | 6.0/52.5m | 3.8 | | | | 5.7 | | | 5.5 | | | 54.0 | |
| 56.0 | | | | 4.0 | | | | 3.6 | | | | 5.4/55.5m | | | 5.2 | | | 56.0 | |
| 58.0 | | | | 3.7 | | | | 3.4 | | | | | | | 4.9 | | | 58.0 | |
| 60.0 | | | | 3.4/58.6m | | | | 3.2 | | | | | | | 4.9/58.4m | | | 60.0 | |
| 62.0 | | | | | | | | 2.9/61.5m | | | | | | | | | 4.5/61.3m | 62.0 | |

※表中の太線で囲まれた部分は、ブーム等の強度によって定められた値です。
ジブ長さ27.4mでの、ボールフックの使用はできません。

(単位:t)

| タワー長さm | 58.0 | | | | | | | | | | | | タワー長さm | |
|--------|------------|------------|-----------|------------|------------|-----------|-----------|-----------|-----------|------------|-----------|------------|-----------|------|
| ジブ長さm | 42.7 | | | 45.7 | | | 48.8 | | | 51.8 | | | ジブ長さm | |
| タワー角度 | 90° | 80° | 70° | 90° | 80° | 70° | 90° | 80° | 70° | 90° | 80° | 70° | タワー角度 | |
| 14.0 | 17.7/14.9m | | | 15.5/15.7m | | | | | | | | | 14.0 | |
| 16.0 | 17.3 | | | 15.5 | | | | | | 13.8/16.5m | | 11.9/17.2m | 16.0 | |
| 18.0 | 16.9 | | | 15.1 | | | | | | 13.4 | | 11.8 | 18.0 | |
| 20.0 | 16.5 | | | 14.7 | | | | | | 13.0 | | 11.4 | 20.0 | |
| 22.0 | 16.1 | | | 14.3 | | | | | | 12.6 | | 11.0 | 22.0 | |
| 24.0 | 15.7 | | | 13.9 | | | | | | 12.2 | | 10.6 | 24.0 | |
| 26.0 | 15.3 | | | 13.5 | | | | | | 11.8 | | 10.2 | 26.0 | |
| 28.0 | 14.9 | | | 13.1 | | | | | | 11.4 | | 9.8 | 28.0 | |
| 30.0 | 14.5 | 11.4/31.9m | | 12.7 | | | | | | 11.0 | | 9.4 | 30.0 | |
| 32.0 | 13.1 | 10.9 | | 12.3 | 10.4/33.2m | | | | | 10.6 | | 9.0 | 32.0 | |
| 34.0 | 11.8 | 10.1 | | 11.9 | 10.0 | | | | | 10.2 | 3.8/34.5m | 8.6 | 8.2/35.7m | 34.0 |
| 36.0 | 10.6 | 9.4 | | 10.7 | 9.3 | | | | | 9.8 | 9.2 | 8.2 | 8.2 | 36.0 |
| 38.0 | 9.5 | 8.8 | | 9.7 | 8.7 | | | | | 9.4 | 8.6 | 7.8 | 7.8 | 38.0 |
| 40.0 | 8.6 | 8.3 | | 8.8 | 8.2 | | | | | 8.9 | 8.1 | 7.4 | 7.4 | 40.0 |
| 42.0 | 7.6 | 7.8 | | 7.9 | 7.7 | | | | | 8.0 | 7.6 | 7.0 | 7.0 | 42.0 |
| 44.0 | 6.1 | 7.3 | | 7.1 | 7.2 | | | | | 7.3 | 7.1 | 6.6 | 6.6 | 44.0 |
| 46.0 | 5.3/44.6m | 6.9 | | 6.1 | 6.8 | | | | | 6.6 | 6.7 | 6.2 | 6.2 | 46.0 |
| 48.0 | | 6.5 | 6.2 | 4.7/47.5m | 6.4 | 5.8/49.7m | 5.8 | 6.3 | | 5.8 | 6.3 | 5.8 | 5.9 | 48.0 |
| 50.0 | | 6.2 | 5.8 | | 6.1 | 5.7 | 4.7 | 6.0 | 5.4/51.5m | 5.1 | 5.6 | | | 50.0 |
| 52.0 | | 5.9 | 5.5 | | 5.8 | 5.4 | 4.1/50.5m | 5.7 | 5.3 | 4.4 | 5.3 | 5.1/53.2m | | 52.0 |
| 54.0 | | 5.6 | 5.3 | | 5.5 | 5.2 | | 5.4 | 5.0 | 3.8/53.4m | 5.0 | 5.0 | | 54.0 |
| 56.0 | | 5.5/54.6m | 5.0 | | 5.2 | 4.9 | | 5.1 | 4.7 | | 4.7 | 4.7 | | 56.0 |
| 58.0 | | | 4.7 | | 5.0/57.6m | 4.6 | | 4.9 | 4.4 | | 4.4 | 4.4 | | 58.0 |
| 60.0 | | | 4.5 | | | 4.4 | | 4.6 | 4.2 | | 4.2 | 4.2 | | 60.0 |
| 62.0 | | | 4.3 | | | 4.2 | | 4.6/60.5m | 3.9 | | 4.0 | 4.0 | | 62.0 |
| 64.0 | | | 4.1 | | | 4.0 | | | 3.7 | | 3.8/63.5m | 3.8 | | 64.0 |
| 66.0 | | | 4.0/64.3m | | | 3.8 | | | 3.5 | | | 3.5 | | 66.0 |
| 68.0 | | | | | | 3.6/67.2m | | | 3.3 | | | 3.3 | | 68.0 |
| 70.0 | | | | | | | | | 3.1 | | | 3.1 | | 70.0 |
| 72.0 | | | | | | | | | 3.1/70.2m | | | 2.9 | | 72.0 |
| 74.0 | | | | | | | | | | | | 2.5/73.1m | | 74.0 |

※表中の太線で囲まれた部分は、ブーム等の強度によって定められた値です。